

ELECTROSTATICS

ELECTROSTATICS

This refers to the study of charges at rest.

To understand the nature of charge, it is necessary to know the structure of an atom.

Structure of an atom

The atom consists of three particles, namely

Particle	Charge	Location
(i) Neutron	No charge	In the nucleus of the atom
(ii) Proton	Positive (+)	In the nucleus of the atom
(iii) Electron	Negative (-)	Outside the nucleus of the atom

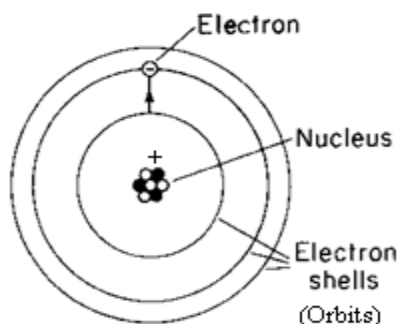

The electrons are negatively charged while protons are positively charged. The two types of charges however are of the same magnitude in a neutral atom.

In a neutral atom, the number of negative charges is equal to the number of positive charges and the atom is said to be electrically neutral. Therefore, electrostatics is the study of static electricity because the charges which constitute it are stationary.

Conductors and insulators

A **conductor** is a material which allows charge to flow through it.

It has loosely bound electrons known as conduction electrons. The flow of these electrons constitutes current flow.

Conduction occurs when electrons transfer charges as they move from one part to another.

Examples: all metals, graphite, acids, bases and salt solutions are conductors.

An **insulator** is a material which does not allow flow of charge through it.

It has no conduction electrons because its electrons are strongly bound by the nuclear attractive forces.

Examples: rubber, dry wood, glass, plastic, ebonite, fur, polythene, sugar solutions etc.

Note: A body (Conductor or Insulator) can lose or gain electrons.

- Loss of electrons leaves the body with a positive charge.
- Gain of electrons leaves the body with a negative charge.

Differences between conductors and insulators

Conductors	Insulators
- Electrons easily move	- Electrons hardly move
- Electrons loosely held	- Electrons tightly held
- The charge acquires is not fixed.	- Charge acquires is fixed

Electrification

This is the process of producing electric charges which are either positive or negative.

Methods of producing Electric charges.

- By friction or rubbing or electron transfer (good for insulators and non conductors).
- By conduction/contact (good for conductors).
- By induction (conductors).

(i) Electrification by friction

- Two uncharged bodies (insulators) are rubbed together. Electrons are transferred from the body to the other.
- The body which loses electrons becomes positively charged and that which gains electrons becomes negatively charged.

Acquire positive charge	Acquire negative charge
-Glass, Fur, Cellulose	-silk, Ebonite (hard rubber), Polythene

Explanation of charging by friction

All insulators do not have electrons arranged in the same way i.e. some insulators have electrons held to them fairly loosely e.g. in glass electrons are held fairly loose compared to silk.

When glass is rubbed with silk, glass tends to lose electrons faster than silk. This results in electrons being lost from atoms of glass at the same time being carried by silk.

The lost electrons from glass are carried by atoms of silk, so glass becomes positively charged and silk becomes negatively charged.

NOTE: The production of charge by rubbing is due to electrons being transferred (lost) from materials where they are less held by the nucleus to the other materials where they are tightly held by the nucleus.

Law of Electrostatics

- Like charges repel each other.
- Unlike charges attract each other.

NOTE: However, attraction between a charged body and any other body DOES NOT necessarily mean that the other body is of opposite charge.

Thus the only SURE/ TRUE test for presence of charge on a body is **repulsion**.

Explanation of attraction between a charged body and an uncharged body

When a negatively charged body is brought near a conductor, induced charges are produced on the conductor.

The negative charges on the conductor are repelled by the negative charge on the rod.

Consequently, the part of the conductor near the rod becomes positively charged and the far end becomes negatively charged.

Because the positive charge on the conductor is nearer the negatively charged rod than the negative charge on the conductor, the attraction between the positive charge and negatively charged rod is greater than the repulsion between the negative charge and the negatively charged rod.

The net force between the rod and the conductor is therefore an attraction. Therefore because of this fact, the only SURE/TRUE test for presence of charge on a body is **repulsion**.

Electrification by conduction i.e Contact method (By sharing excess electrons)

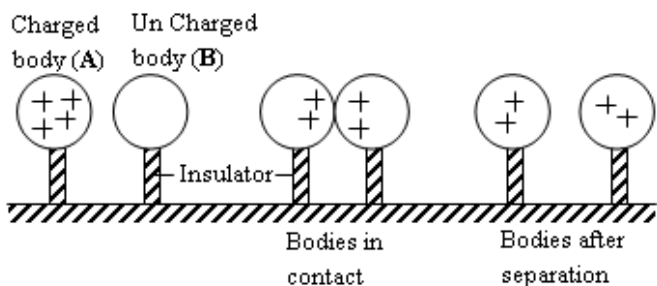

- Support the uncharged conductor on an insulated stand.
- Put a positively charged rod in contact with the conductor.
- Because of mutual repulsion between the positive charges in the rod, some of them are converted or transferred to the conductor.
- When the conductor is removed from the rod, it is found to be positively charged.

NOTE:

- ❖ The negative charges (electrons) migrate from the uncharged body to the charged body until the positive charge on both of them is the same.
- ❖ Sphere B acquires a positive charge because it has lost electrons while sphere A is still positive but it is left with less positive charges.
- ❖ The insulated stand prevents flow of charge away from the conductor.
- ❖ To charge the conductor negatively, a negative rod is used.

Electrification by induction (By Electrostatic induction)

Electrostatic Induction is the acquisition of charges in an uncharged conductor from a charged body placed near it but not in contact with it.

Facts about charging a conductor by induction.

- ❖ Bringing a charging rod near the conductor to be charged.

A charged body is brought near one end of the conductor to be charged without touching it.

It induces charges on the conductor. That is electrons are either repelled or attracted to one end.

- ❖ Earthing the side of the conductor remote to the charging rod in presence of the charging rod.

The other side of the conductor is earthed to allow inflow or out flow of electrons from or to the earth.

- ❖ Breaking the earth connection in presence of the charging rod.

While the charged body is still in position, the earth line disconnected.

- ❖ Removing the charging rod

The charged body is then removed and the net charge distributes itself all over the conductor.

Note: The charge obtained is always opposite to that of the charging body.

(a) Charging the body positively.

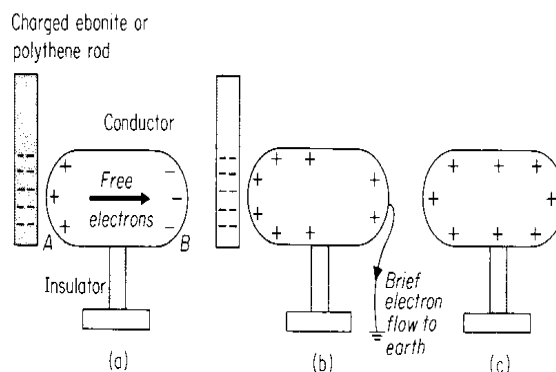

Procedure:

- Bring a negatively charged rod near the conductor placed on an insulated stand. The positive and negative charges separate as shown in (a)
- In presence of the charged rod, earth the conductor by momentarily touching it at the side furthest from the charging rod with a finger. Electrons flow from it to the earth as shown in (b).
- In presence of the charged rod, disconnect the earth line and then remove the charged rod.
- The conductor is found to be positively charged.

(b) Charging the body by induction negatively,

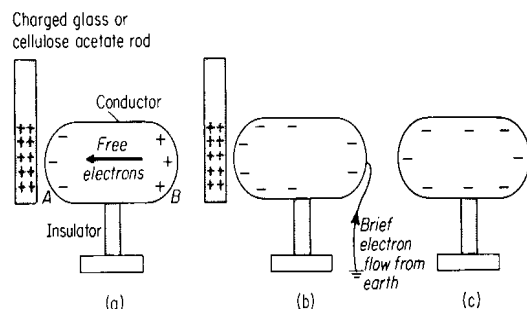

Procedure:

- Bring a positively charged rod near the conductor placed on an insulated stand. The positive and negative charges separate as shown in (a)
- In presence of the charged rod, earth the conductor by momentarily touching it at the side furthest from the charging rod with a finger. Electrons flow to it from the earth as shown in (b).
- In presence of the charged rod, disconnect the earth line and then remove the charged rod.
- The conductor is found to be negatively charged.

Charging two bodies simultaneously:

(i) Such that they acquire same charges.

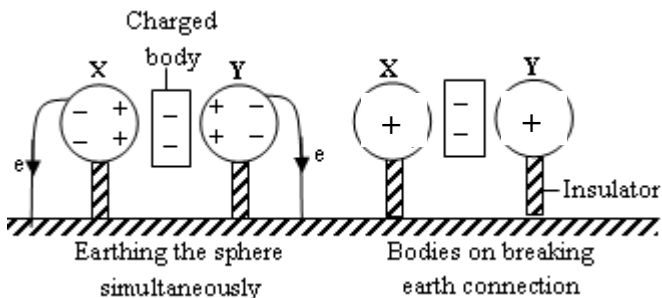

- Two identical metal X and Y are supported by insulating stands.
- A negatively charged rod is placed between the two metal spheres.
- Positive charges in each sphere are attracted towards the negatively charged rod and negative charges (electrons) are repelled to the side remote to the charging rod.
- In presence of the charging rod, both conductors are earthed at the same time by touching the sides remote to the charging rod.
- On earthing the sphere, electrons flow to the ground. When the earth is disconnected, the radial spheres are left with positive charge.
- When the charging rod is withdrawn, the positive charge on the spheres distributes themselves over the entire surface of the sphere.

(ii) So that they acquire the an opposite charge

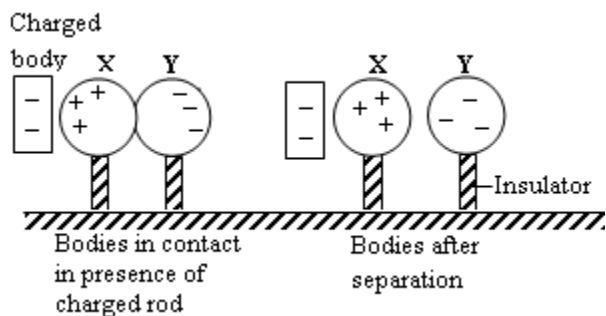

- Support two uncharged bodies, X and Y on an insulated stand and then place them in contact as shown in (a)

- Bring a positively charged rod near the two bodies, positive and negative charges separate as in (b).
- Separate, X from Y in presence of the inducing charge.
- Remove the inducing charge, X will be positively charged and Y will be negatively charged.

The gold leaf electroscope

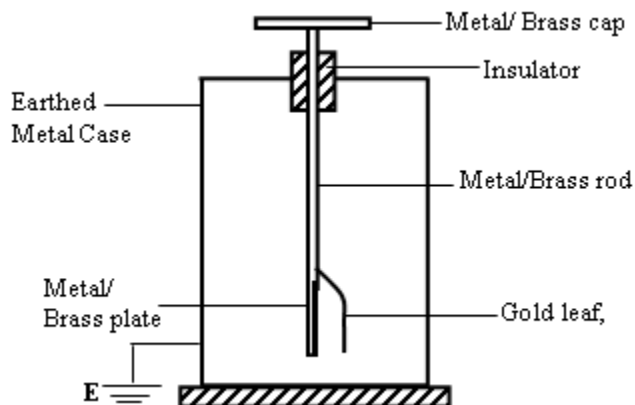

- It consists of a brass cap and brass plate connected by a brass rod.
- A gold leaf is fixed together with a brass plate with a brass.
- The brass plate, gold leaf and part of brass rod are put inside a metallic box which is enclosed with glass windows.

Mode of action

- When a charged body is brought near or in contact with the cap of the electroscope, the cap will acquire an opposite charge to that on the body by induction.
- The charge on the body will repel all charges similar to it down to the metal rod, to the plate and the leaf.
- Due to presence of like charges on the plate and gold leaf, the leaf diverges as it is repelled by the plate.
- Leaf divergence implies that the body brought near or in contact with the cap carries a charge.

Charging a gold leaf electroscope by induction.

(i) Charging it positively

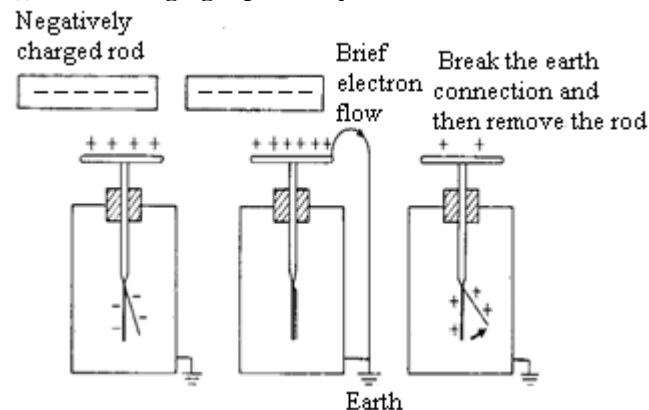

- Bring a negatively charged rod near the cap of the gold leaf electroscope.

- Positive charges are attracted to the cap and negative charges are repelled to the plate and gold leaf.
- The leaf diverges due to repulsion of the same number of charges on the plates.
- Earth the gold leaf electroscopes in presence of a negatively charged rod.
- Electrons on the plate and leaf flow to the earth.
- The leaf collapses.
- Remove the negatively charged rod, positive charges on the cap spread out to the rod and leaf therefore the leaf diverges hence the gold leaf is positively charged.

(ii) Charging it negatively.

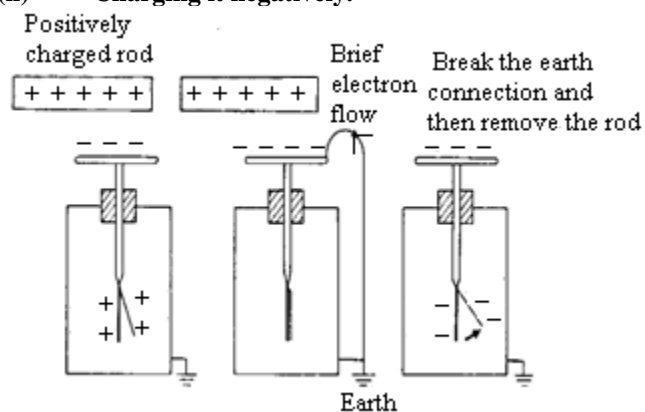

- Get an uncharged gold leaf of electroscope.
- Bring the positively charged rod near the gold leaf cap.
- Negative charges are attracted to the cap and positive charges are repelled to leaf and glass plate.
- Earth the gold leaf electroscopes in presence of a positively charged rod.
- Negative charges flow from the earth to neutralize positive charges on plate and leaf.
- The leaf collapses.
- Remove the positively charged rod, negative charges on the cap spread out on the leaf plate, therefore, the leaf diverges and a gold leaf therefore becomes negatively charged.

Uses of a Gold leaf Electroscope

1. To detect the presence of charge on a body.

Bring the body under test near the cap of a **neutral G.L.E.**

If the leaf deflects, then the body has got a charge.

However, if the leaf remains un-deflected, then the body is neutral (has no net charge).

2. To test the nature or sign of charge on a body.

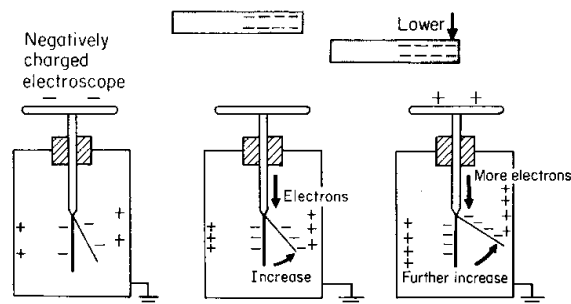

Bring the body under test near the cap of a **charged G.L.E.**

If the leaf diverges further, then the body has a charge similar to that on the G.L.E.

However, if the leaf collapses, then the body is either neutral or it carries a charge opposite to that on the G.L.E. In this case, we cannot conclude. But the G.L.E is discharged by touching its cap with a finger and then given a charge opposite to the one it had previously and the experiment is repeated. If still the leaf collapses, then the body is neutral.

NOTE: An increase in leaf divergence is the only sure test for the sign of charge on a body.

Increase in leaf divergence occurs when the test charge and the charge on the gold leaf electroscope are the same.

3. To compare and measure potentials.

Two bodies which are similarly charged are brought in contact with the cap of a G.L.E one after the other.

The divergences in the two cases are noted and compared.

The body which causes more divergence is at a higher potential.

4. To classify conductors and insulators.

Bring the body under test in contact with the cap of a **charged G.L.E.**

If the leaf collapses suddenly, then the body is a good conductor.

If the leaf collapses gradually, then the body is a poor conductor. The leaf collapses due to charge leakage.

If the leaf **does not collapse**, then it is an **insulator**.

Distribution of charge on a conductor.

Surface density is the quantity of charge per unit area of the surface of a conductor.

- ❖ The distribution of surface density depends on the shape of the conductor.
- ❖ It is investigated using a gold leaf electroscope and a proof plane (a small metal disc with a handle made of insulator).
- ❖ The surface conductor is touched using a proof plane. The proof plane is then transferred to an electroscope by allowing it to touch the cap of the G.L.E.

- ❖ The angle of leaf divergence is noted and it gives a rough measure of the charge transferred and hence the magnitude of surface density at that point.

Experimental results show that:

- Charge density is greatest at the most curved point.
- Charge always resides on the outside of a hollow conductor.

(a) Hollow conductor

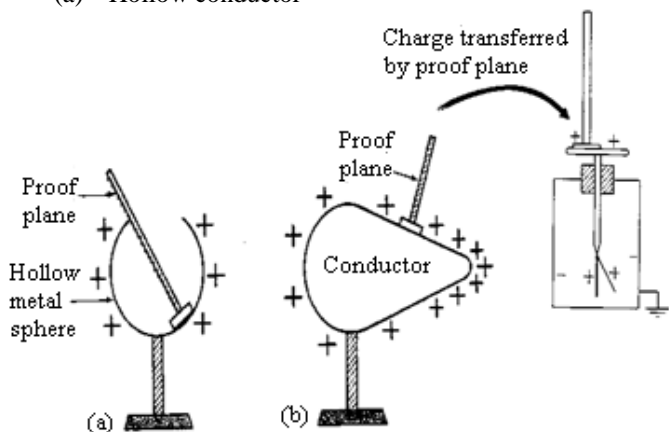

When the proof plane is placed on the outside surface of a charged hollow conductor, charge is transferred to the uncharged G.L.E, the leaf diverges as shown in (a). This proves that charge was present on the outside of the surface.

When the proof plane is placed on the inside of a charged conductor is transferred to the uncharged G.L.E, the leaf does not diverge as in (b) therefore, charge resides on the outside surface of the hollow charged conductor.

(b) Curved bodies

A curve with a big curvature has a small radius and a curve with small curvature has big radius therefore, curvature is inversely proportional to radius. A straight line has no curvature.

Surface charged density is directly proportional to the curvature. Therefore a small curvature has small charge density. Surface charge density is the ratio of charge to the surface area.

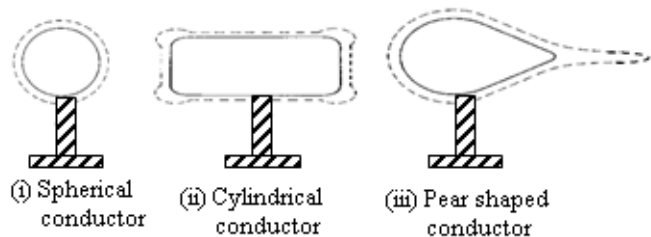

Action of points

Charge concentrates at sharp points. This creates a very strong electrostatic field at charged points which ionizes the surrounding air molecules producing positive and negative ions. Ions which are of the same charge as that on the sharp points are repelled away forming an **electric wind** which may

blow a candle flame as shown in the diagram below and ions of opposite charge are collected to the points.

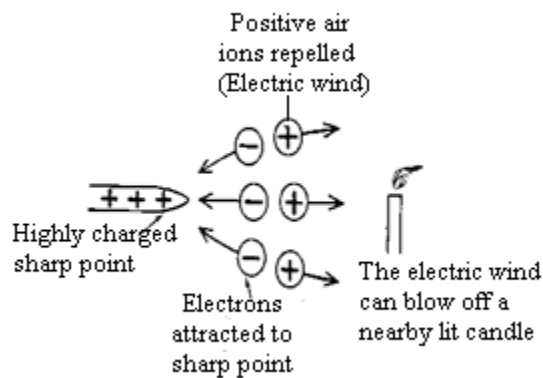

Therefore, a charged sharp point acts as;

- Spray off of its own charge in form of electric wind.
- Collector of unlike charges.

The spraying off and collecting of charges by the sharp points is known as **corona discharge** (action of points.)

Application of action of points (corona discharge)

- Used in a lightening conductor.
- Used in electrostatics generators.
- Electrostatic photocopying machines.
- Air crafts are discharged after landing before passengers are allowed. Air crafts get electrified but charge remains on the outer surface.

Lightening

A lightening is a gigantic (very large) discharge between clouds and the earth, or between the charges in the atmosphere and the earth.

A lightening conductor:

Lightening conductor is a single component in a lightening protection system used to safe guard tall building from being destroyed by lightening.

It provides a safe and easy passage of charge to the earth hence safe guarding the building.

A lightening conductor is made up of:

- Spikes** placed high up on a tall building.
- copper strip** which is fixed to the ground and on the walls of the tall building ending with several
- Copper plate** buried under the grounded

How it works

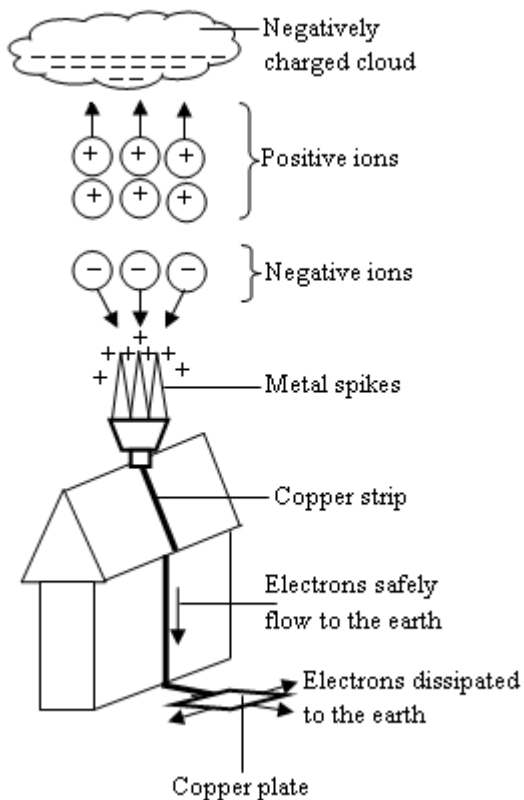

- A moving cloud becomes negatively charged by friction.
- Once it approaches the lightning conductor, it induces opposite charge on the spikes of the conductor.
- A high charge density at pointed ends creates a large electric field intensity which ionizes the air molecules such that the negative ions are attracted at the spikes and sends a stream of positively charged ions which neutralize some of the negative charges of the cloud.
- The excess negatively charged ions are safely conducted to the earth through a copper strip hence reducing the harmful effect of the cloud.

Faraday's Ice pail experiment

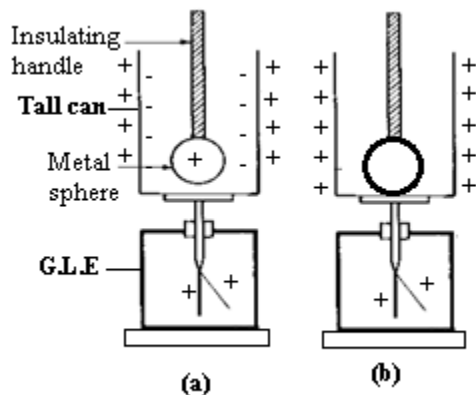

- A metal sphere is suspended by an insulating thread and is given say a positive charge.

- The sphere is then lowered into a tall metal can connected to an uncharged electroscope as shown in (a). The leaves of the electroscope are observed to diverge.
- The metal sphere is shifted to various positions inside the can but without touching its surfaces. the divergence θ on the electroscope is observed to remain the same.
- The sphere is withdrawn from the can and the leaf of the electroscope collapses. The sphere is again lowered into the can and the leaf of the electroscope is observed to diverge by the same amounts as before.
- The sphere is then allowed to touch the inner surface of the can. The divergence θ is observed to remain constant.
- The sphere is then withdrawn and tested for charge. It is found to have lost all its charge, showing that there must have been an equal negative charge on the inner surface of the can which neutralized the positive charge on the sphere.

Conclusions from Faradays' experiment.

- ✓ A charged metal object suspended inside a neutral metal container induces an **equal but opposite charge** on the inside of the container.
- ✓ When the charged sphere touches the inside of the container, the induced charge exactly neutralizes the excess charge on the sphere.
- ✓ When a charged body is suspended within a metal container, an equal charge of the same sign is forced to the outside of the container.

Electric fields

This is a region around the charged body where electric forces are experienced. Electric fields may be represented by field lines.

Field lines are lines drawn in an electric field such that their directions at any point give a direction of electric field at that point. The direction of any field at any given point is the direction of the forces on a small positive charge placed at that point.

Properties of electric field lines

- They begin and end on equal quantities of charge.
- They are in a state of tension which causes them to shorten.
- They repel one another sideways.

Field patterns

(a) Isolated charges

(i) Isolated positive charge

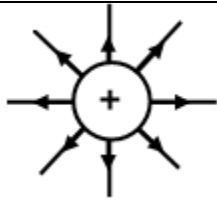

Field lines point away from the charge.

(ii) Isolated negative charge

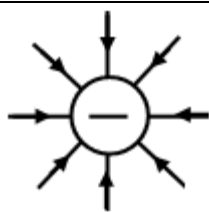

Field lines point towards the negative charge.

(b) Unlike charges close together

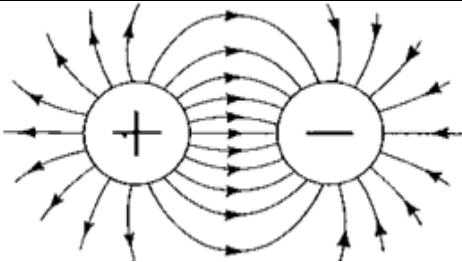

The lines of force connect from positive charge to negative charge.

(c) Like charges close together

The field lines repel sideways.

(i) like positive charges

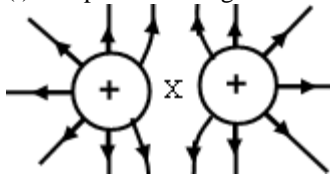

(ii) like negative charges

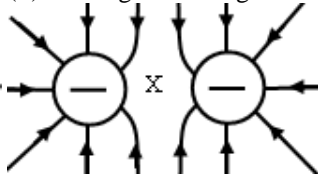

(d) Two charged plates/ a charged plate and a point charge

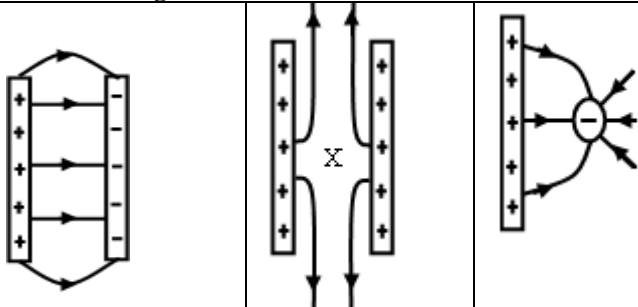

Exercise:

1991 Qn.2	2005 Qn.34	2002 Qn.30
1997 Qn.28	2008 Qn.6	2005 Qn.5
1998 Qn.28	Lightning & Electric fields	2006 Qn.33
1999 Qn.31	1992 Qn.21	2007 Qn.32
2000 Qn.35	1994 Qn.14	1988 Qn.17
2001 Qn.22	1995 Qn.26	
2004 Qn.10	1998 Qn.40	
2005 Qn.28	2000 Qn.17	

SECTION B

1989 Qn. 60

(a) Sketch the electric field patterns for the following;

- Two negative charges close to each other
- A positively charged conducting sphere
- Two oppositely charged parallel plates

(b) Explain the following observations;

- The leaves of a positively charged gold leaf electroscope fall when the cap is touched.
- When a positively charged conductor is lowered in an ice pail placed on the cap of an uncharged electroscope, the leaves diverge. When the conductor touches the inside of the pail, the divergence of the leaves is not altered.

(c) Explain how a lightning conductor safe guards a house against lightning.

1990 Qn.8

- Draw a well labeled diagram of a gold leaf electroscope.
- Describe an experiment to test the charge on a charged body using a gold leaf electroscope.
- Draw electric field patterns for;
 - Two positively charged bodies at a small distance apart.
 - An isolated negative charge.

1991 Qn.7

- State the law of electrostatics.
- Describe how two identical metal balls may be charged positively and simultaneously by induction.
- Explain what happens when a negatively charged rod is brought near the cap of an uncharged electroscope and slowly taken away.
 - Briefly explain how an electroscope can be used to test whether a material is a conductor or an insulator.
- What precautions should be taken when carrying out experiments in electrostatics?

1994 Qn.7

- Explain why a pen rubbed with a piece of cloth attracts pieces of paper.
- A positively charged metallic ball is held above a hollow conductor resting on the cap of a gold leaf electroscope. Explain what happens to the leaf of the electroscope as the ball is lowered into the hollow conductor.

1998 Qn.10

- Explain what happens to an insulator when it is rubbed with another insulator of different material?
- The figure below shows a conductor supported on an electrical insulator. The conductor is given some positive charge.

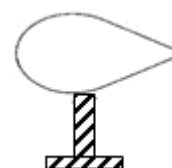

Show how the charge is distributed on the conductor.

(c) Sketch the electrical field pattern due to two unlike charges **P** and **Q** below.



2005 Qn.4

- (a) Describe how you would use a gold leaf electroscope to determine the sign of a charge on a given charged body.
- (b) Explain how an insulator gets charged by rubbing.
- (c) Sketch the electric field pattern between a charged point and a metal plate.