



Dr. Bbosa Science Based on, best for sciences

This document is sponsored by
The Science Foundation College Kiwanga- Namanve
Uganda East Africa
Senior one to senior six
+256 778 633 682, 753 802709

Movement and support

Locomotion

One of the characteristic of living thing is movement. This is obvious in animals but less obvious in majority of plant, Movement enable animals to look for food, mates and escape predators.

1. For movement to be possible there must be a form of support. In plant especially, the young one is the turgor pressure; In old dicots it's the woody tissue while in animals it's the skeletal tissue.

2. The skeleton

There are three types of skeleton

(a) Hydrostatic skeleton

Here support is provided by a fluid under pressure and it is found in round worms, earth. Here the coelom of the body is filled with fluid under pressure and the muscle surrounding the coelom contract against the skeleton

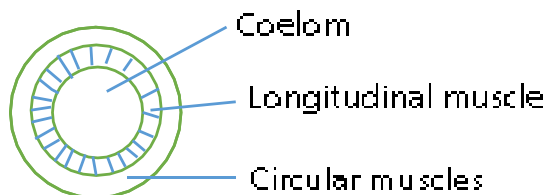

Movement in earthworm

The body wall of earthworm contains muscles which contract against the fluid in the coelomic body cavity, creating a pressure which maintain the animal shape in much the same way as a balloon's shape is maintained when full of air. There are two antagonistic set of muscle tissue in the body wall; **Circular and longitudinal muscle**. When the circular muscles contract, the longitudinal muscles relax, the body become long and thin, when the longitudinal muscle contract the circular muscle relax the body becomes short and fat.

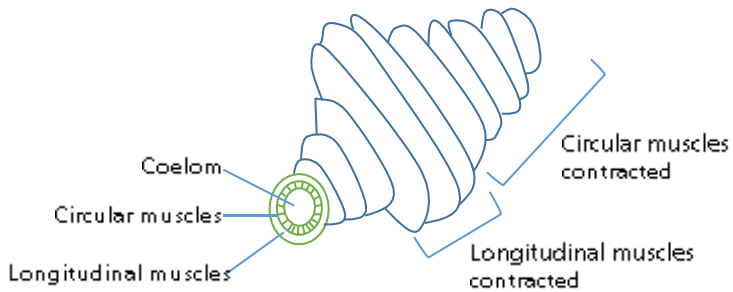

Transverse septa divided the body cavity into a series of watertight compartment [segment]. This means that a change in pressure in one part of the body doesn't immediately spread to other parts, so localized bulges can occur. Locomotion is achieved by these bulges being propagate along the body.

(b) Exoskeleton

It is made of a hard cuticle protecting inner delicate tissues and also provides attachment for muscles

Insects thorax contain two sets of antagonistic flight muscle; a pair of dorso-ventral muscle (indirect muscle- not attached to the wing) run from the roof to the floor of the thorax; and a pair of longitudinal muscles run from the anterior surface of the dome- like roof to the posterior surface. When the dorso-ventral muscle contract the roof attachment of the wing is pulled downwards to the wall attachment with a result that the wing goes up. When the longitudinal muscles contract the top of the dome – like roof rises slightly and the roof attachment is pulled upwards relative to the wall attachment with the result that the wing goes down.

Action of muscle in raising and lowering wings

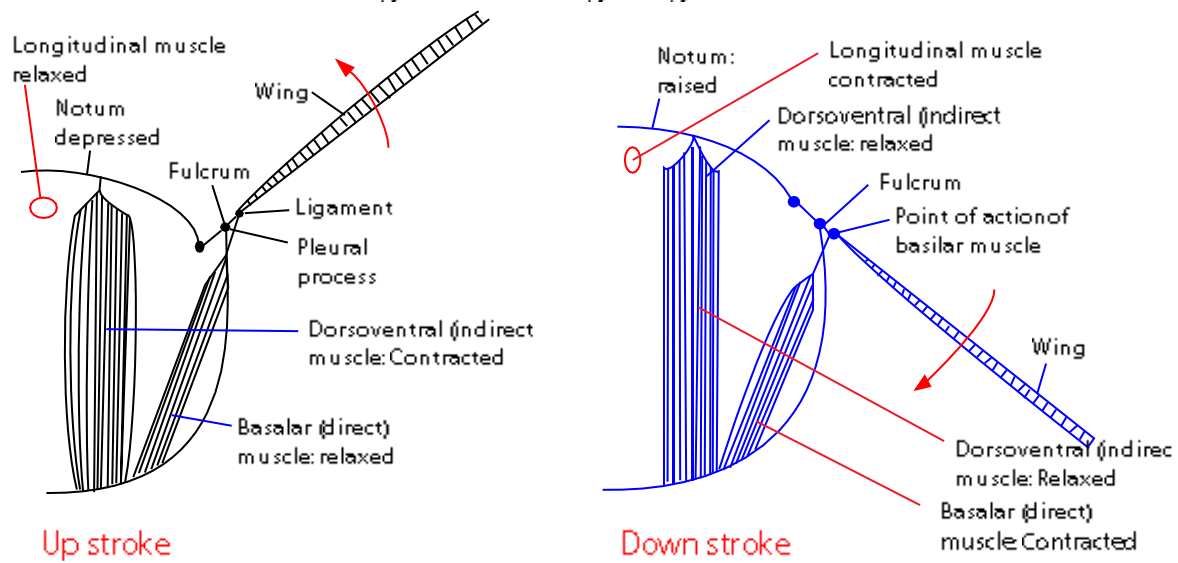

Advantage of exoskeleton

1. It minimize water loss by evaporation
2. It protects the internal soft tissue
3. It determine maximum size of the organism

Disadvantage

It limits the rate of growth of the organism.

(c) Endoskeleton

It occurs in vertebrates, made of bone and cartilages.
It is internal and the muscles are outside

Advantages-

-does not interfere with the rate of growth

Disadvantage

Do not protect all soft tissue.

Skeleton

is the framework of bone in the body

Skeleton

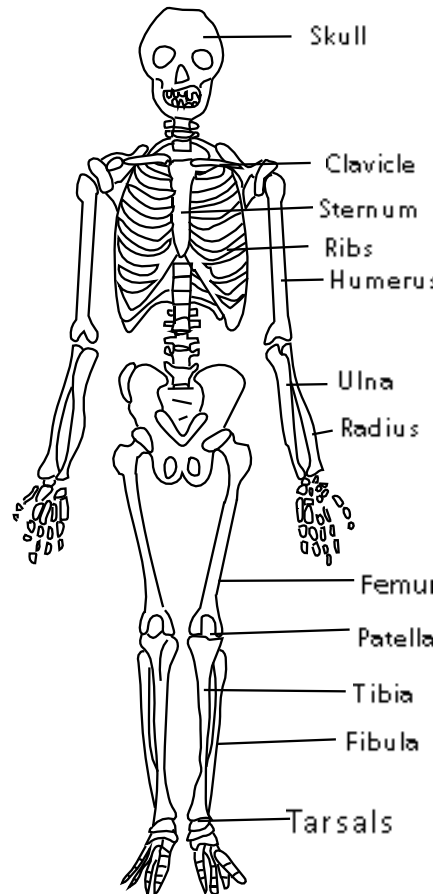

BONES

Those are hard tissue that make up a skeleton

Functions of bone

- (a) Give body shape for easy identification
- (b) Provide support
- (c) Protect delicate organs
- (d) Store Minerals Ca,
- (e) Make blood cells

Joints

A joint is a place where joint meet.

Types of Joint

1. pivot joint allows rotation movement e.g. neck
2. Hinge joint allow movement of bone in two planes e.g. knee, elbow and finger joints
3. ball and socket joints at the shoulder and hip allow movement in many directions
4. Saddle is similar to hinge joints but allow more movements, e.g. thumb.
5. Plane or gliding joints are associated with small bones and allow movement in many directions e.g. ankle and wrist.
6. condyloid between ulna and radius at the wrist.

Structure of synovial joint

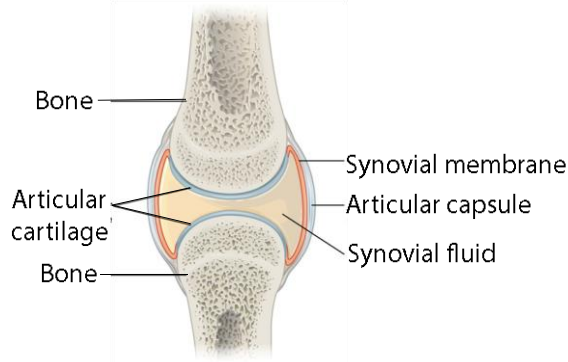

Muscles

A muscle is a band or bundle of fibrous tissue in a human or animal body that has the ability to contract, producing movement in or maintaining the position of parts of the body.

Types of muscle

The **3 types of muscle** tissue are

- (i) cardiac located in the heart walls
- (ii) smooth muscles in visceral structures under involuntary control. **Smooth muscle** generally forms the supporting tissue of blood vessels and hollow internal organs, such as the stomach, intestine, and bladder.
- (iii) skeletal muscles attached to bone under voluntary control.

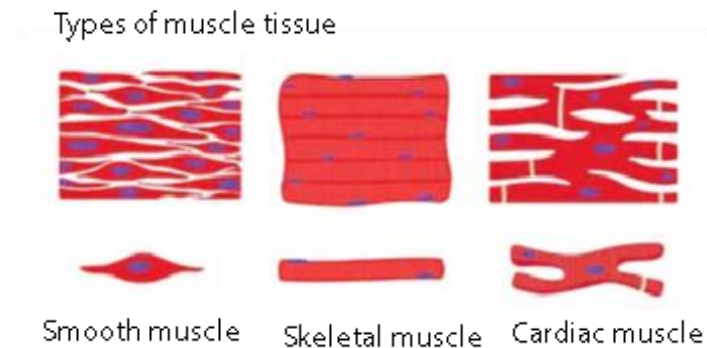

Differences between smooth and skeletal muscles

	Smooth muscles	Skeletal muscles
1.	Not striated	striated
2.	involuntary	Voluntary
3.	Not under conscious control	Under conscious control
4.	Found within walls of internal organ	Attached to bones e.g. biceps

Differences between Smooth Muscles and Cardiac Muscles

	Cardiac muscles	Smooth muscle
1.	Striated	Not striated
2.	Found in heart wall	Found in internal organs
3.	innervated by the autonomic nervous system via its cardiac pacemaker	are directly innervated
4.	do not regenerate	Regenerate when injured

Differences between cardiac and skeletal muscles

	Skeleton muscle	Cardiac muscle
1.	controlled by the somatic nervous system	involuntarily controlled
2.	cells are cylindrical in shape	are semi-spindle in shape
3.	are attached to the bone	is found in the heart
4.	skeletal muscle cells are multi-nucleated.	only one or two nuclei in the cardiac muscle cells
5	Has no gap junction	Has gap junction
6	Few mitochondria	Many mitochondria

Antagonistic muscles

Muscles responsible for movement by contracting and relaxing against the skeleton are referred to as antagonistic muscles, i.e., when one is contracted the other is relaxed. For example, in human arm when the biceps flex and the triceps extends the arm out.

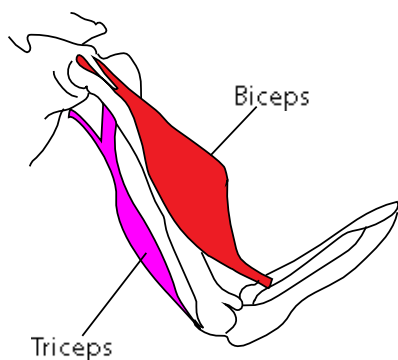

When the biceps contract it bends and curls the arm

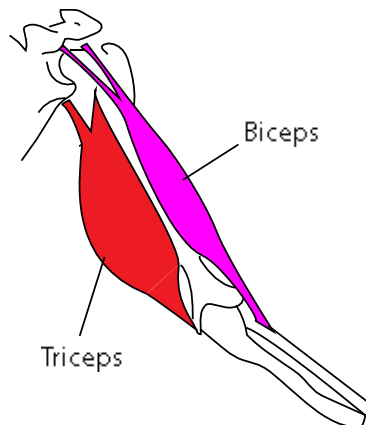

When the triceps contract it straightens the arm

Locomotion

For locomotion in animals three things are required.

- Propulsion; The animals must be propelled with sufficient force in the appropriate direction.
- support; The animal must be supported by its body acting against the particular medium in which it leaves
- Stability; The animal may become temporarily unstable while moving but eventually stability must be restored

Propulsion on land

The legs of land- living vertebrates contains numerous muscle most of which are directly or indirectly involved in propulsion. In propelling the body forward, the most important muscles are the retractors and extensors. When they contract the limb acts a level, lifts the body off the ground and propels the body forward.

Support on land

The limbs hold the body off the ground both when the animal is in motion and when it is standing still. Limbs that are directly beneath the body are more efficient for the purpose.

Stability on land

For a tetrapod at rest, with its four legs planted fairly and squarely on the ground, stability is not a major problem.

During motion, when only three legs are on ground is when the problem arises. To keep the centre of gravity under the triangle of the 3 remaining legs on ground, the sequence of movement of legs is left hind leg is lifted and brought behind the left fore limb. Then left fore limb is lifted and placed out in front. Then right hind limb followed by fore limb are also brought forward. For instance, in the tetrapod below

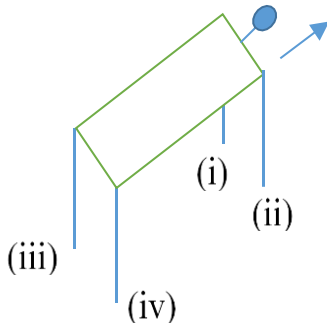

The order of movement of legs is (i), (iv), (ii), (iii) Or (ii), (iii), (i), (iv) or (iii), (i), (iv), (ii),

Locomotion in water.

Water is the densest medium in which living organism can live. It consequently offers a lot of resistance to them. However, the aquatic organisms have adapted themselves in two ways.

1. Have stream lined body to resistance

2.Their bodies are covered with mucus which lubricates the body.

Support in fish.

Bony fish are made buoyant by a gas filled swimming bladders by adjusting the amount of air in these bladder the fish is able to stay at a required depth.

Cartilaginous fish such as shark do not possess a swimming bladder of any kind. They sink if they stopped swimming, support comes from the process of swimming itself.

Presence of a swimming bladder makes bony fish better swimmer than sharks

Propulsion in fish.

In most fish propulsion comes from the side -to- side lashing of the tail which is equipped with a caudal fin for increasing the surface area. These movements are brought about by contraction of antagonistic and segmentally arranged muscle called myotomes.

The tail sweeps from side to side by alternate contraction of the myotomes on each side of the body. The myotomes on the left and right side are of course antagonistic and their contractions are coordinated by the CNS.

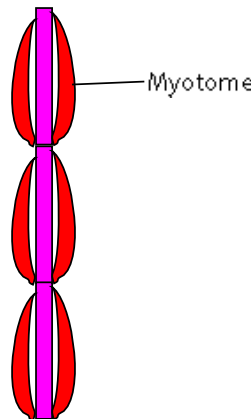

Stability in fish

A fish is liable to the same kind of instability that affect boats, yawing, pitching and rolling

1. Yawing, the side-to- side oscillation of the front part of the body resulting from propulsion action of the tail, is counteracted by the general massiveness and inertia of the head and the pressure of water against the side of the body and the vertical fins. In many bony fishes the stabilizing effect of the feature is enhanced by lateral flattening of the body.
2. Pitching the tendency of the front end to plunge vertically downwards, is counteracted by the flap- like horizontal fins. The large the surface area of these fins have, the more effective they are as stabilizers.
3. Rolling, the rotation of the body about the longitudinal axis, is counteracted by both the vertical and horizontal fins.

Locomotion in air.

Here the medium provides little support

Adaptive of bird aid flight

- (i) has feather that aid flight
- (ii) hollow bone to reduce weight
- (iii) bones are fused to reduce flexibility
- (iv) lightweight, smooth feathers – this reduces the forces of weight and drag
- (v) a beak, instead of heavy, bony jaws and teeth – this reduces the force of weight
- (vi) an enlarged breastbone called a sternum for flight muscle attachment – this helps with the force of thrust
- (vii) a streamlined body – this helps reduce the force of drag
- (viii) wings – these enable the force of lift.

Front view of a penguin skeleton showing the origin and insertion of the flight muscles

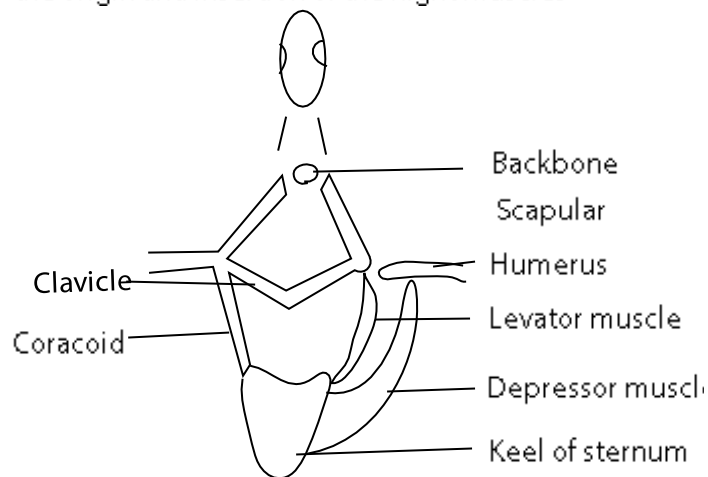

Active flight

The bird fly by flapping the wings.

The large and powerful depressor muscle pulls the wing downwards and give the bird lift during active flight, when the Levator muscle contract it pulls the wing upwards.

- (i) Joints are fused to reduce flexibility

The muscle

A whole muscle is made up hundreds of muscle fibers which vary in length. An isolated fiber is filled with a specialized cytoplasm called sarcoplasm in which about 100 nuclei are spaced out evenly just beneath the bounding membrane or sarcolemma. Numerous parallel striation transverse the fiber from one side to another

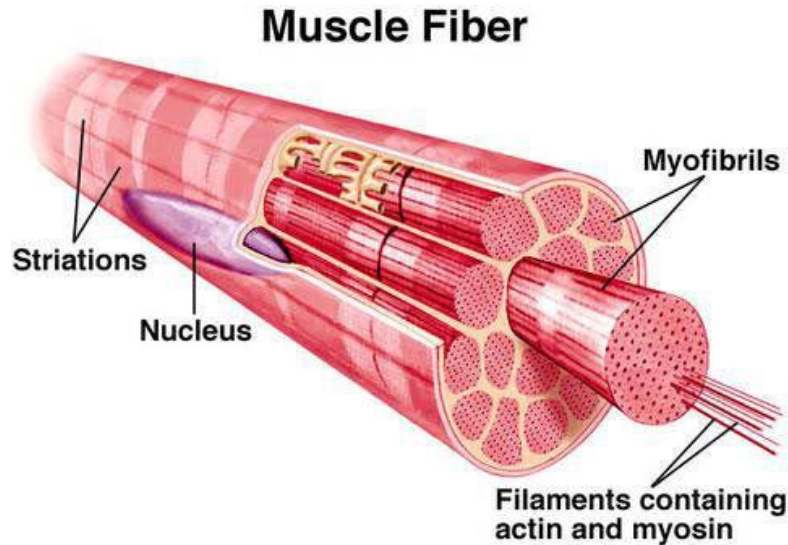

The fine structure of muscle

Each muscle fiber contains several hundreds of small units of myofibrils.

When one individual myofibril is observed under an electron microscope the striations are seen as light and dark bands. Each dark band has comparatively light region in the middle and it's called the H-zone

There are dark regions on either side of the H-zone. Running across the middle of the H-zone is the dark line called the M- line and traversing the middle the light band is an even dark line, the Z- line. The region of a myofibril from one Z line to the next is called sarcomere [the basic unit of the myofibril].

The explanation of the banding pattern is done in the figure below.

Sarcomere

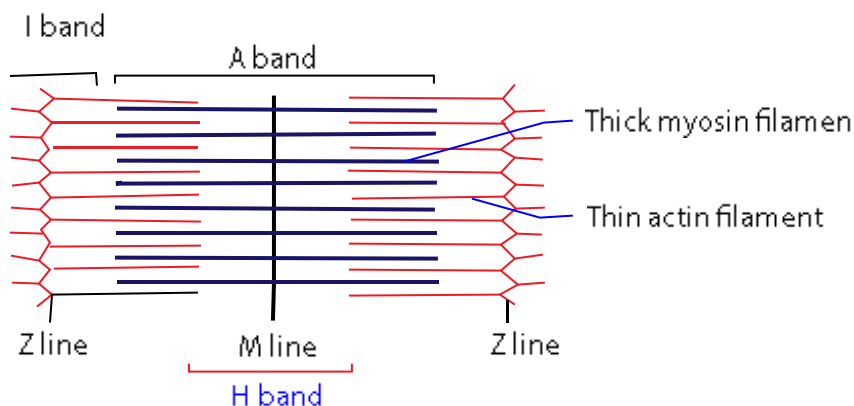

The myofibril is composed of numerous longitudinal filament, the thick and thin ones. The thick filament is confine to the dark band. The thin filaments occur in the light band, but extent in between the thick filaments into the dark band. The area on either side of the H- zone and therefore particularly dark because they contain both thick and thin filaments. The H- zone consist of thick filament only.

Chemical nature of a muscle

It contains two protein actin and myosin. The thick filaments are composed of myosin and the thin filament actin.

How muscle contract

- a. Skeleton muscle contraction is initiated by arrival of a nerve impulse at the nerve muscle junction.
- b. Arrival of the nerve impulse cause influx of calcium ions into the pre-synaptic knob leading to release of acetylcholine from pre-synaptic knob into the synaptic vesicle.
- c. acetylcholine depolarizes the muscle fiber
- d. the impulse generated thereof is transmitted via T-tubules through sarcoplasm.
- e. Ca^{2+} are released from sarcoplasmic reticulum to the muscle fibre.
- f. Calcium ions initiates contraction of muscles by binding troponin
- g. Tropomyosin shift from actin binding site
- h. myosin heads get instantly attached to the binding sites on actin filament and contraction of muscles occurs.

Relaxation phase

- a. After action potential has cholinesterase is released and breaks down acetylcholine.
- b. Sarcolemma & T-tubules repolarized
- c. the calcium gates close, and calcium pumps located on the sarcoplasmic reticulum remove calcium from the cytoplasm.
- d. As the calcium gets pumped back into the sarcoplasmic reticulum, calcium ions come off the troponin.
- e. The troponin returns to its normal shape and allows tropomyosin to cover the actin-myosin binding sites on the actin filament.
- f. Because no binding sites are available now, no cross bridges can form, Passive sliding of filaments occur and the muscle relaxes.

Exercise

1. A rigid cuticle of an insect allows some movement because

- A. it is made of chitins which makes the limb flexible.
 - B. during molting enzymes dissolve the old cuticle as a new one formed
 - C. the overlapping plates of cuticle are not continuous at the joints
 - D. the exoskeleton is periodically shed off for the insect to move
2. Which one of the following is not true of a contracted muscle fiber?
- A. M-line shortens
 - B. sarcomere shortens
 - C. H-zone shortens
 - D. light bands shorten
3. during locomotion in a tetrapod, which of the following is the correct order of movement of limbs after the animal has moved its left hind limb?
- A. Left fore, right hind, right fore
 - B. left fore, right fore, right hind
 - C. Right hind, left fore, right fore
 - D. Right fore, left fore, right hind
4. The figure below is a cross section of a thorax showing flight muscle in insect

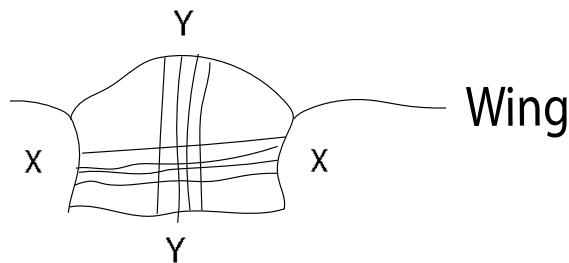

Which action of muscle lowers the wing?

- A. Relaxation of Y
 - B. Contraction of Y and relaxation of X
 - C. contraction of X
 - D. Contraction of X and relaxation of Y
5. The fusion of parts of the vertebral column in birds, aids flight by
- A. restricting flexibility
 - B. reducing weight
 - C. strengthening the skeleton
 - D. reducing friction
6. Sprinters usually take off at an angle rather than in an upright position in order to increase
- A. the speed of movement
 - B. the upward force
 - C. effective length of the limbs
 - D. forward force
7. The figure below represents a longitudinal section through part of a striated muscle fibre.

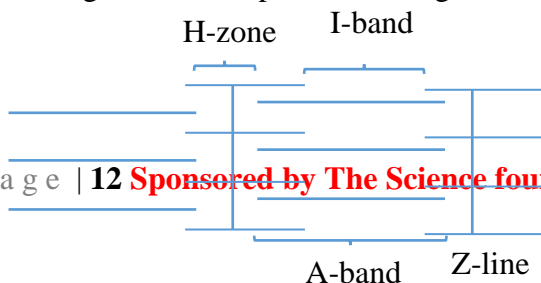

Which one of the following pairs of structures shorten when the muscle fibers contract?

- A. I-band and H-zone
- B. H-zone and A-band
- C. I-band and Z-line
- D. A-band and Z-line

8. The figure shows an earthworm in stationary position

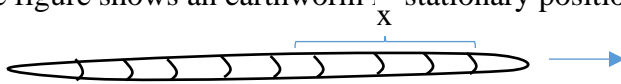

For the earthworm to progress in the direction indicated by the arrow, in region X, the earthworm has to contract its

- A. Circular muscle and extend its chaetae
- B. Longitudinal muscles and retract the chaetae
- C. Circular muscles and retract the chaetae
- D. Longitudinal muscles and extend the chaetae

9. The role of calcium ions in muscle contraction is to enable

- A. Tropomyosin bind myosin
- B. Actin to bind to myosin
- C. Myosin binds on actin
- D. Tropomyosin bind on actin

10. The figure below is a simplified diagram of a tetrapod in stationary position

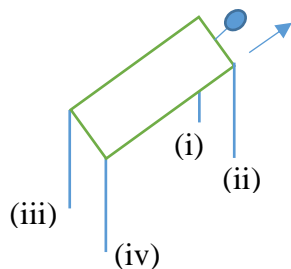

Which one of the following would be the correct order of limbs movement the tetrapod if it is to move in the direction shown?

- A. (ii), (iv), (iii), (i)
- B. (i), (iv), (ii), (iii)
- C. (ii), (iv), (iii), (i)
- D. (iii), (iv), (ii), (i)

11. Which of the following features in a bony fish makes it more efficient in swimming than a cartilaginous fish?

- A. Strong bony skeleton
- B. Highly coordinated neuromuscular acuity

- C. Swimming bladder
- D. Streamline body

12. The figure shows the banding pattern of a myofibril when relaxed

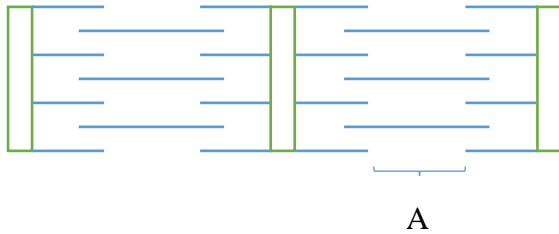

Which of the following occurs in reference to the A band when the myofibril is contracted?

- A. Become lighter
 - B. Becomes narrower
 - C. Disappears
 - D. Become wider
13. A layer of wax is deposited over chitin in exoskeleton because
- A. Wax reduces the weight of the exoskeleton
 - B. Chitin is permeable to water
 - C. Wax allows flexibility of the body
 - D. Chitin alone is not hard enough for protection
14. Which pair of structures counteracts the instability due to rolling in fish?
- A. Vertical and horizontal fins
 - B. Mass of head and vertical fins
 - C. Body flattening and caudal fin
 - D. Streamline body and horizontal fins
15. Which of the following occurs during contraction of a skeletal muscle?
- A. I-band become shorter
 - B. A- hand become longer
 - C. Sarcomere remains unchanged
 - D. H-zone become wider
16. During locomotion, bones of a tetrapod are subjected to the following forces except
- A. Shearing
 - B. Compression
 - C. Tension
 - D. expansion
17. During locomotion in an earthworm, when longitudinal muscles contract in a region, the region become?
- A. thin and short
 - B. thin and long
 - C. thick and long
 - D. thick and short
18. Which one of the following is the correct shape, in the region of the body of an earthworm where its circular muscles are contracted?
- A. Short and thick

- B. Long and thin
 - C. Short and thin
 - D. Long and thick
19. Which one of the following movements in fish is counteracted by the vertical fins?
- A. Rolling
 - B. Backward drag
 - C. Pitching
 - D. Yawing
20. During flight in insects' upstroke is brought about by
- A. Contraction of direct muscles
 - B. Relation of indirect muscles
 - C. Contraction of indirect flight muscles
 - D. Sudden up thrust of the body
21. Which one of the following is not a function of skeleton in insects?
- A. Support of body
 - B. Protection of delicate body parts
 - C. Prevention of desiccation
 - D. Secretion of wax
22. The flagellum and skeletal muscle are structurally similar in that they both have
- A. Microtubules
 - B. Actin and myosin
 - C. A pattern of 9+2 microtubules
 - D. Light and dark band
23. Contraction of longitudinal muscles in insects during flight results into
- A. Flapping of wing
 - B. Moving down of wing
 - C. Holding wings horizontally
 - D. Moving wings up
24. The fusion of parts of the vertebral column in birds aids flight by
- A. Strengthening the bones
 - B. Reducing body weight
 - C. Restricting flexibility of the body
 - D. Reducing friction between bones
25. Which one of the following correctly describes the state of the muscle in an earthworm in a region of the body that is being moved forward?
- A. Circular muscles are contracted and longitudinal muscles relaxed
 - B. Both circular muscles and longitudinal muscles are relaxed
 - C. Both longitudinal and circular muscles are contracted.
 - D. Longitudinal muscles are contracted and circular muscles relaxed
26. The figure represents a tail of a fish in water

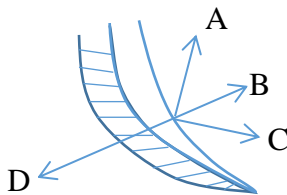

Which arrow represents the force applied against the water by the tail of the fish as the muscles in the shaded side contract?

27. The figure shows a transverse section through the thorax of an insect

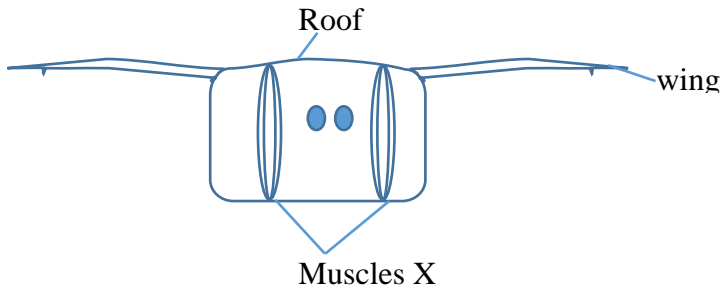

Which of the following is the correct state of the roof of the thorax and the direction of the wing when muscles X contract?

	State of the roof of thorax	Direction of wing beat
A	Raised	Upstroke
B	Flattened	Up stroke
C	Raised	Down stroke
D	Flattened	Down stroke

28 The figure below shows part of an earthworm in locomotion

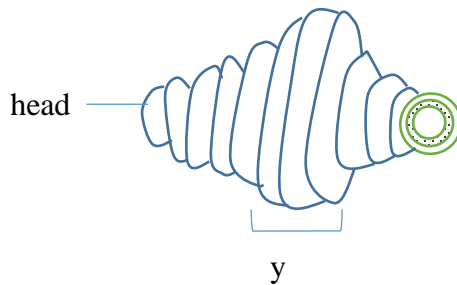

In which state are the circular and longitudinal muscles in the region labelled Y?

- A. Circular muscles are contracted and longitudinal muscle relaxed
- B. Longitudinal muscles are contracted and circular muscles relaxed
- C. Circular and longitudinal muscles are relaxed
- D. Circular and longitudinal muscles contracted

29. The figure represents a tetrapod in motion

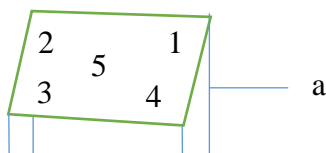

If the animal lifted limb a during its movement, in which position would it shift its centre of gravity in order to remain most stable?

- A. 2
- B. 3
- C. 4
- D. 5

30. Which one of the following sections of strained muscles in figure below represents a myofibril in a contracted state?

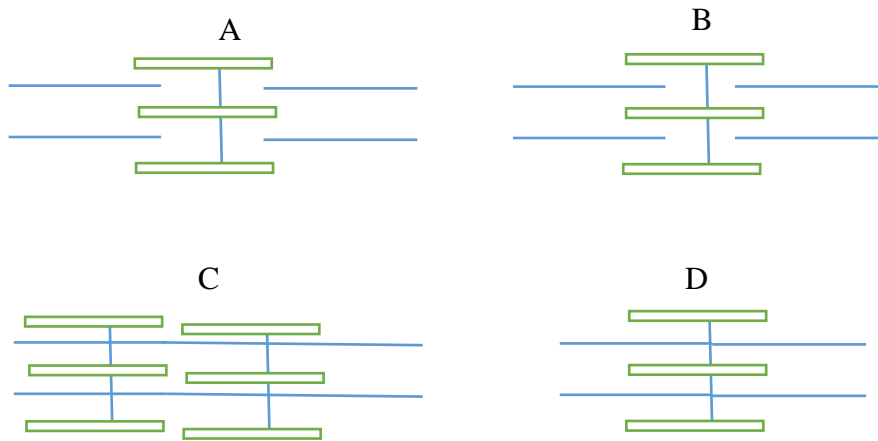

Figure 1

31. Which one of the following describes what happens at the tip of a newly formed amoeboid pseudopodium?

- A. Gel ectoplasm changes to sol endoplasm
- B. Gel endoplasm changes to sol ectoplasm
- C. Sol ectoplasm changes to gel endoplasm
- D. Sol endoplasm changes to gel endoplasm

32. Which of the following would counteract rolling in bony fish?

- A. Dorsal flattening of the body
- B. General massiveness of the head
- C. Pressure of water against the sides of the body
- D. Vertical and horizontal fins

33. Which of the following have joint of the hinge type?

- A. Knees, shoulders
- B. Fingers, hips
- C. Shoulders, elbow
- D. Elbows, knees

34. Which of the following is the correct arrangement of microtubules in a cross section of a flagellum?

- A. 9 +0
- B. 9+4

- C. 9+2
D. 9+1
35. Which one of the following pairs of proteins is found in skeletal muscle?
A. Actin and myosin
B. Keratin and actin
C. Myosin and fibrinogen
D. Myosin and collagen
36. Yawing in tilapia is counteracted by
A. Dorsal and ventral fins
B. Caudal fin
C. Pectoral fins
D. Pectoral and caudal fins
37. Sprinters usually take off at an angle rather than in upright position in order to increase
A. The speed of movement.
B. The upward force.
C. Effective length of the limbs.
D. Forward force
38. A likely effect of inhibiting the action of; cholinesterase at a synapse is
A. Cessation of impulse transmission.
B. Speeding up of impulse transmission.
C. Continuous impulse transmission.
D. Slowing down of impulse transmission

Essay questions

40. (a) what problems of support and locomotion do terrestrial animal face? (04marks)
(d) (i) How do support achieved in woody plants? (06marks)
(ii) Describe the changes that take place in a cell that eventually develops into a xylem vessel element. (10marks)
41. (a) Describe structural adaptations in birds which have enabled them have successful aerial life (12marks)
(b) How does flight in birds differ from that of insects. (08marks)
- 42 (a) Give an outline of the classification of muscular tissue. (1 ½ marks)
(b) Describe the structures of the phloem and cardiac muscles (4 ½ marks)
(c) Explain how the structures of the phloem and cardiac muscles are related to their functions. (14marks)
42. Discuss how structure and function are related for each of the following tissues
(a) Voluntary muscle tissue (10marks)
(b) Parenchyma tissue in plants (10marks)
43. (a) How does a skeletal muscle differ from a smooth muscle? (5marks)
(b) Describe the process of skeletal muscle contraction (10marks)

Suggested answers

1	C	5	A	9	C	13	B	17	D	21	D	25	A	29	B	33	D	37	D
2	A	6	D	10	B	14	A	18	B	22	A	26	B	30	D	34	C	38	C
3	A	7	A	11	C	15	A	19	A	23	B	27	B	31	A	35	A		
4	A	8	A	12	B	16	D	20	C	24	C	28	B	32	D	36	C		

39. (a) Problems of support and locomotion in terrestrial animals.

(ix) Terrestrial animals face a problem of supporting the weight of their bodies against the force of gravity

(x) The force of gravity which tends to pull the animal's body towards the ground also makes locomotion hard.

(xi) The low density of air provides little support to animals

(xii) Wind blows animal's body, thus compromising the support mechanisms.

(b) (i) How is support achieved in woody plant?

- In young woody plants, support is provided by the turgidity of the cells and the cellulose cell walls.
- In young woody plants, support is provided mainly by the lignified xylem vessels, tracheid and sclerenchyma tissue
- The walls of the xylem vessels and tracheid are thick and lignified. This hardens them, thus giving tensile strength and rigidity to the plant.
- The secondary thickening in the xylem cells deposit more wood to xylem or tissue to provide greater support in stems and roots.
- Support is enhanced by the central distribution of the xylem in the root. This helps to withstand the tugging strains of the aerial parts as they bend
- In the stem, xylem vessels exist as separate rod through the entire stem hence offering support against bending.
- Sclerenchyma tissue has thick and lignified cellulose cell walls which are impermeable to water, thus giving strength to the stem.

(ii) Development of xylem

- The cell undergoes cell elongation by osmotic uptake of water leading to irreversible expansion of the cell wall
- The horizontal end walls break down partially or completely so that the cells is in open communication with the neighboring cell
- The cellulose side walls become impregnated with lignin, making them impermeable to water solutes.
- The protoplasmic contents of the cell die, leaving a hollow tube.
- Its lignified walls become perforated with numerous pits in places where lignin is not deposited
- These pits may bordered by a lignified rim, making them bordered pits
- As the cell develop, lignified ribs of different types are laid down on the immediate inside of the walls. This leads to spiral and annular thickening.
- The cell has now developed into a xylem vessel element.

40. (a) Structural adaptations of birds for aerial life.

- (i) Birds have a well streamlined body shape. This allows them to move smoothly in the air without much resistance.
- (ii) They have a keel-shaped sternum for attachment of flight muscles.
- (iii) They have few mobile joints. This makes their bodies compact so that they can move smoothly as a whole in the air with less resistance.
- (iv) They have hollow bones to reduce on their weight so as to float well in the air during flight.
- (v) Their wings are shaped like an aerofoil. This helps them to generate enough force to initiate and maintain flight.
- (vi) Down feathers as are filthy to provide high insulation.
- (vii) The bones of vertebral column are fused to reduce flexibility and provide a firm attachment for muscle.
- (viii) Flight feathers are large and strong to provide a large surface area for generation of force of flight and to resist strong air currents during flight.
- (ix) Ability to fold the legs away during flight further streamlines their body shape and reduces air resistance.

(x) They have prominent eyes located dorso-laterally on the head to provide a keen eye sight especially during landing.

(xi) have scale on the legs to reduce water loss

(b). Differences between the flight of birds and insects

Flight in birds	Flight in insects
<ul style="list-style-type: none"> • All use direct muscles. • Rate of wing beat per second is low • Air penetrates wing to reduce resistance • Muscles are attached on endoskeleton • Wing is thick, made up of bones, muscles and covered by feather • Keel extension for muscle attachment • Supply of oxygen to active muscles is indirect; through blood • Turbulence is prevented by bastard wing • Flight muscles have myoglobin 	<ul style="list-style-type: none"> • Some use indirect muscles • Rate of wing beat per second is high • Air does not penetrate wing • Muscles are attached on exoskeleton • Wing is thin, membranous and made of chitin; no feather • Muscles are attached to tergum and sternum • Supply of oxygen to active muscles is direct; through tracheal system. • Some insect orders have halteres to prevent turbulence. • Flight muscles lack myoglobin

41. (a) Muscular tissues include

- (i) Skeletal or striated muscle.
- (ii) Cardiac muscle
- (iii) Smooth or unstriated muscle.
- (iv) Voluntary and involuntary muscles

(b) Structure of phloem

- This is a vascular conducting tissue whose structure is composed of sieve tubes, phloem

parenchyma and companion cells.

- Sieve tubes are living, slender, elongated tubular cells connected end-to end. Their cell walls are thin but made up of cellulose. They have large cavities with transverse walls obliquely placed and perforated with numerous sieve pits. These are called sieve plates. The cells have no nuclei but the living layers of protoplasmic strands have direct continuous connection through sieve pits from one cell to another.
- Companion cells are living, elongated, thin walled cells with prominent nuclei and dense cytoplasm lying close and parallel to the sieve tubes.
- Phloem parenchyma and sclerenchymatous fibers lay in association with other cells giving them support.

(ii) Structure of cardiac muscle.

- This consists of a network of branched muscle fibers in the walls of the heart.
- The fibers are short, cylindrical, branching and separated by loose connective tissue rich in blood capillaries.
- The fibers are joined end-to end and are interconnected by oblique bridges to form zig-zag junctions called intercalated discs.

(c). (i) Adaptations of the phloem to its functions

- (i) The sieve tube cells are elongated, tubular and placed end to end to form a continuous channel for transportation of materials.
- (ii) Plasmodesmata are enlarged to reduce resistance to flow of food materials
- (iii) The sieve plates are perforated by numerous pores to allow the passage of materials from one sieve element to the next.
- (iv) The sieve tube cells have no nuclei hence avail more space for translocation.
- (v) The companion cells are highly metabolic to sustain needs of the sieve tube.
- (vi) Phloem parenchyma aids in the storage of food and in controlling slow conduction.
- (vii) Phloem fibers provide mechanical support and rigidity to plant organs.

Cardiac muscle.

- (i) The intercalated discs allow fast transmission of impulse from one fiber to the another by

allowing rapid passage of ions. This allows spread of an impulse through the muscle.

- (ii) The numerous blood capillaries quickly deliver oxygen and nutrients to the muscles and remove wastes to allow the muscles to contract without fatigue.
- (iii) The fibres contain actin and myosin which contract.
- (iv) The fibres branch and cross-connect with each other allowing the entire heart to behave as a unit.

42. Discuss how structure and function are related for each of the following tissues

- (a) Voluntary muscle tissue (10marks)
- (b) Parenchyma tissue in plants (10marks)

Solution:

(a) Adaptation of voluntary muscle tissues

- (i) Voluntary muscle tissues in animals act as a component of the locomotory apparatus. They are usually attached to bone, a structure for to be involved in locomotion
- (ii) Each muscle fibre consists of numerous fibres containing numerous, long cylindrical, unbranched and elastic myofibrils. This allows the muscle to exert a wide range of influence when it contracts. The elasticity also allows it to regain its original length after stretching.
- (iii) The myofibrils are arranged parallel to one another. This allows them to slide over one another during contraction and relaxation.
- (iv) Each muscle fibre has intimate connection with the motor portion of the voluntary nervous system. This enables it to respond to actions of this section of the nervous system in response to changes in the environment.
- (v) The muscle has a dense network of blood capillaries. This ensures efficient supply of oxygen and nutrient to, and removal of waste product of respiration from, the muscle. This improves efficiency of the muscle.
- (vi) Muscle fibre is surrounded by T-tubule that facilitates potential propagation.
- (vii) The muscle contains myoglobin instead of haemoglobin in the blood. Myoglobin has a higher affinity for oxygen than haemoglobin. This ensures that enough oxygen is provided to muscle even at low oxygen tensions of the blood flowing through the muscle.

(viii) The fluid bathing the myofibrils contains numerous glycogen granules and mitochondria. This ensures that enough energy, in form of ATP, is always available to the muscle for use in contraction.

(b) Adaptation of parenchyma tissue

- (i) Parenchyma tissue is an aggregate of living isodiametric cells which forms the background tissues. It is the major component of stems of non-woody plants.
- (ii) In the peripheral region of green plants, certain parenchyma cells contain chloroplast and called chlorenchyma. Here it takes part in the manufacture of food by the plants.
- (iii) Parenchyma's have a cellulose cell wall that allows passage of water during water transport.
- (iv) The inelasticity of cellulose provides support to the plant when the parenchyma is rigid.
- (v) In many aquatic plants and petioles of some land plants, parenchyma cells develop large intercellular spaces called aerenchyma. This provides buoyancy and help in floating. It also allows for gaseous exchange.
- (vi) Parenchyma cells have an inelastic cellulose wall such that when they elongate and become turgid after absorption of water, the parenchyma is rigid, this makes the stems turgid and offer support to non-woody plants.
- (vii) Succulent parenchyma found in xerophytes has large stores of water and functions as water storage tissue.

43 (a) Differences between skeletal muscle fiber and smooth muscle fiber

	Skeletal muscles	Smooth muscles
1.	Move under voluntary influence	Move involuntarily
2.	Fatigued easily	Not usually fatigued
3.	Straited muscles	Non straited muscle
4.	Muscles attached to bones	Muscles found in visceral walls
5.	Cells are short and thick	Cells are long and thin
6.	Contract rapidly	Contract slowly

(b) The process of skeletal muscle contraction

- a. Skeletal muscle contraction is initiated by arrival of a nerve impulse at the nerve muscle junction.

- b. Arrival of the nerve impulse cause influx of calcium ions into the pre-synaptic knob leading to release of acetylcholine from pre-synaptic knob into the synaptic vesicle.
- c. acetylcholine depolarizes the muscle fiber
- d. the impulse generated thereof is transmitted via T-tubules through sarcoplasm.
- e. Ca^{2+} are released from sarcoplasmic reticulum to the muscle fibre.
- f. Calcium ions initiates contraction of muscles by binding troponin
- g. Tropomyosin shift from actin binding site
- h. myosin heads get instantly attached to the binding sites on actin filament and contraction of muscles occurs.

Relaxation phase

- a. After action potential has cholinesterase is released and breaks down acetylcholine.
- b. Sarcolemma & T-tubules repolarized
- c. the calcium gates close, and calcium pumps located on the sarcoplasmic reticulum remove calcium from the cytoplasm.
- d. As the calcium gets pumped back into the sarcoplasmic reticulum, calcium ions come off the troponin.
- e. The troponin returns to its normal shape and allows tropomyosin to cover the actin-myosin binding sites on the actin filament.
- f. Because no binding sites are available now, no cross bridges can form, Passive sliding of filaments occur and the muscle relaxes.