

PRIMARY WORK BOOK

ESSENTIAL BACK UP TOOL FOR SUCCESS

ESSENTIAL BACK UP TOOL FOR SUCCESS IS A SERIES OF LEARNING THE SOURCE MATERIALS ORGANISED FOR USE AFTER THE TEACHER HAS INTRODUCED AND EXPLAINED THE CONCEPT TO THE LEARNER.

ESSENTIAL BACK UP TOOL FOR SUCCESS COVERS PRIMARY SYLLABUS FROM **PRIMARY ONE TO PRIMARY SEVEN** IN ALL SUBJECT ASPECTS THAT IS ENGLISH, SOCIAL STUDIES, INTEGRATED SCIENCE, MATHEMATICS, LITERACY (FOR LOWER CLASSES) AND RELIGIOUS EDUCATION.

THIS TOOL IS WELL SUMMARISED WITH RELEVANT EXPLANATIONS, FOLLOW UP EXERCISES AND ACTIVITIES IN LINE WITH TERM ONE WORK AS PRESCRIBED BY THE NATIONAL CURRICULUM DEVELOPMENT CENTER , UGANDA.

EACH OF THE ABOVE ASPECTS HAS A VARIETY OF DIFFERENT FORMS OF ACTIVITIES TO ENHANCE MASTERY.

THIS WORK BOOK IS ORGANISED BY MARKS GATE INTERNATIONAL (MGI) IN CORROBORATION WITH STANDARD HIGH SCHOOL ZZANA (STAHIZA)

THIS TOOL HAS SERIES IN TERMS THAT IS (TERM ONE, TERM TWO, TERM THREE)

Here in is an extract of the material that compose a whole book. In case you are interested in the complete sets of books, contact; 0772511120/0705283741

PRIMARY ONE LITERACY WORK BOOK FOR TERM ONE

OUR SCHOOL

What is a school?

A school is a place where we go to learn or study.

Parts of a school.

- door
- office
- windows
- classrooms
- ventilators
- verandah
- iron sheets
- glasses
- timber
- steps

Structure of a school

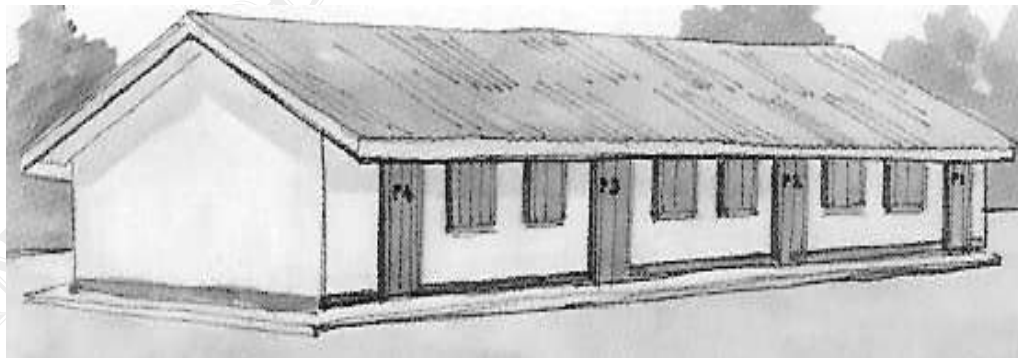





Things found at school

- pens
- tables
- swings
- balls
- files
- blackboards
- uniforms
- spoons
- books
- pieces of chalk
- benches
- cups

- pencils
- bells
- cupboards
- plates
- forks
- school van
- rulers
- trees
- chairs
- dusters
- cups
- saucepans
- brooms
- flowers

Things found in a school

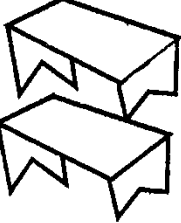
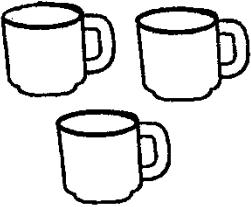
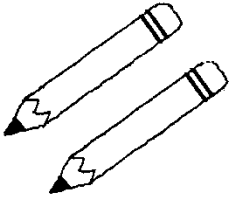
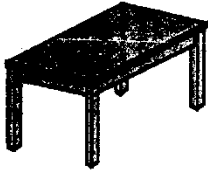
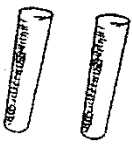
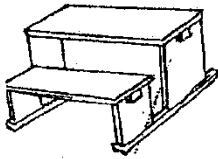
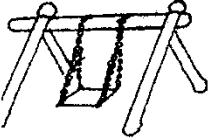
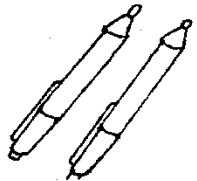
Plates	School uniforms	school van	book
			
benches	Cups	Pencils	table
			
Chalk	desk	swings	pen
			









Things found in the classroom.

- desks
- pencil
- blackboard
- duster
- piece of chalk
- rulers
- charts
- brooms
- tables

People found in our school

- teacher
- children
- askari
- head teacher
- secretaries
- cleaner
- cooks
- bursar
- school nurse
- matron

People found in our school

<p>Teacher</p> 	<p>Children</p> 	<p>Cleaner</p> 
<p>Cook</p> 	<p>Bursar</p> 	<p>Askari</p> 
<p>Head teacher</p> 	<p>School nurse</p> 	<p>matron</p> 

People found at school and their work.

Matrons	:	care for the children in a school
Head teacher	:	heads a school
Cook	:	cooks food at school
Cleaners	:	keep the school clean.

Things used by people at school;

Teacher	-	chalk, text books, pens
Cook	-	mingling stick
Askari	-	bow and arrow/gun
School nurse	-	syringe and medicine
Cleaners	-	brooms, rags, scrubbing brush
Bursar	-	calculator, receipt book, computer
Secretary	-	papers, computer
Head teacher	-	computer, stamp, files, pens, books
Store keeper	-	keys
Matrons	-	soap, water, rag

Uses of school property

brooms	-	for sweeping
pen/pencils	-	for writing
books	-	for writing in
chairs	-	for sitting on
dusters	-	for cleaning the chalkboard
beds	-	for sleeping on
chalk	-	for writing on the chalk board
clock	-	for telling time.

Evaluations questions

1. Draw and name four examples of school property.

2. Write down any three needs of a school.

(i) _____ (iii) _____

(ii) _____

3. Name these school property

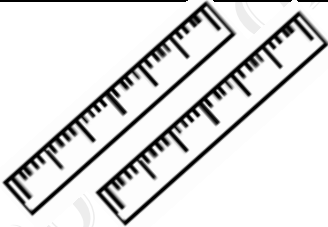
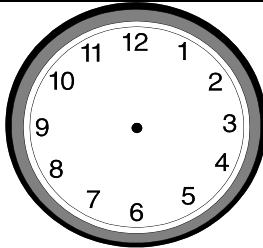
 _____		

1. Mention any four useful objects in a school.

(i) _____ (iii) _____

(ii) _____ (iv) _____

2. How are the following items useful in a classroom?

a) broom _____

b) duster _____



c) clock _____

d) chairs _____

3. Draw and name any three useful things in our school

Examples of personal property

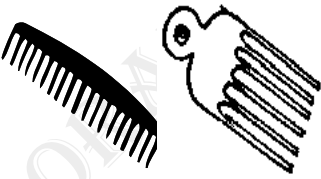
- toothbrush, towel, sponge, comb, pants, shoes etc

		
Sponge	Comb	Shoes

Uses of personal property

- Toothbrush – for brushing our teeth.
- Comb – for combing our hair.
- Sponge – for bathing
- Towel – for drying our body

Evaluations questions

1. Mention any four examples of personal property

(i) _____ (iii) _____

(ii) _____

(iv) _____

2. Match the following correctly.

toothbrush

for combing our hair.

towel

for brushing our teeth.

sponge

for drying our body.

comb

for bathing.

3. Draw these examples of personal property

toothbrush	sponge	comb

Activities done in our school

-singing

-sweeping

-dancing

-reading

-praying

-writing









-running

-playing



-drumming



ACTIVITIES AT SCHOOL

Dancing	Reading	Praying
----------------	----------------	----------------

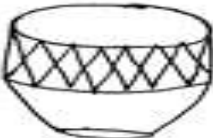
		
Sweeping the classroom	Running	Playing
		
Writing	Eating	
		

Materials children use to do activities at school.

		
Drum	Book	Bible

		
Pencil	Broom	Ball

How we keep the school clean

- By sweeping the compound
- By mopping the classroom
- By picking the rubbish
- By burning the rubbish
- By cleaning the toilets
- By slashing the compound
- By cleaning desks and chairs

Things used to keep the school clean.

- | | | |
|-------------|-----------|---------|
| - brooms | - soap | - water |
| - scrubbing | - rag | - hoe |
| - brushes | - slasher | |

ACTIVITY

1. What is a school? _____

2. A _____ is a place where we go to learn or study.
3. Name the place where we go to learn or study. _____
4. Write four parts of a school.
(i) _____ (ii) _____





(iii) _____ (iv) _____

5. Give four things found at school.

(i) _____ (ii) _____

(iii) _____ (iv) _____

6. Draw these things found in a school.

benches	pencils
	
A book	table
	

7. Name four things found in a classroom.

(i) _____ (ii) _____

(iii) _____ (iv) _____

8. Name four people found in a classroom.

(i) _____ (iii) _____

(ii) _____ (iv) _____

9. A _____ teaches pupils in a class.

10. Who heads a school? _____

11. _____ cooks food at school.

12. A _____ cleans the school.
13. Who treats sick pupils at school? _____
14. _____ care for children in a school.

NB: What you have finished is a **small part** of the material that compose a **whole book**. In case you are **interested** in the complete set of this book, contact; **0772 511 120/ 0705 283 741**