



KINGS WAY PRIMARY SCHOOL

P. 4 RECESS REVISION 2020-(SET FIVE)

ENGLISH

DURATION : 2 HOURS 15 MINUTES

NameStream

Read the following instructions carefully

1. This paper is made up of two Sections: A and B.
2. Section A has 50 questions (50 marks)
3. Section B has 5 questions (50 marks)
4. Attempt all questions. Answers to both sections must be written in the spaces provided.
5. All answers must be written in ink. Crossing out of answers will lead to loss of marks.
6. Any handwriting that cannot be easily read may lead to loss of marks.

FOR EXAMINERS USE ONLY		
QN. NO.	MARK	SIGN
1-10		
11-20		
21-30		
31 – 40		
41 – 50		
51		
52		
53		
54		
55		
TOTAL		

SECTION A
SUB-SECTION 1

For questions 1-4, fill in the blanks with the most correct word.

1. hasndmeo _____
2. mastr _____
3. fuleubita _____
4. guyl _____

For questions 5-10, use the correct form of the words in brackets to complete the sentences

5. I am _____ my work in pencil. (write)
6. Tomusange was the _____ in the end of year examination. (two)
7. The teacher told the head boy to speak _____. (loud)
8. Okurut and Apio _____ to the market next week. (go)
9. Our dog has given birth to three _____. (puppy)
10. Of the two girls, Genevive is the _____. (thin)

For questions 11-15, use the most suitable word to complete the sentences.

11. It is a bad act to laugh _____ lame people.
12. My sister has gone to a _____ to have her teeth treated.
13. Most children _____ rice and meat to posho and beans.
14. _____ that girl or this boy has broken our teacher's table.
15. The teacher _____ taught us last year has died.

For questions 16-18, arrange the words in alphabetical order.

16. axe, donkey, book, camel.

17. flu, flag, flew, floor.

18. shell, she, shelf, sheep

For questions 19-20, write the following abbreviations in full

19. won't _____

20. o'clock _____

For questions 18-20, rewrite the sentences giving the plural form of the underlined words.

21. Our school furniture is broken.

22. That tall lady is our new teacher of English.

23. Sick people should eat on avocado rather than oranges.

In questions 24-26, rewrite the following in words.

24. 40th _____

25. 25th _____

26. 9th _____

For questions 27- 28, re-write the sentences giving the opposite of the underlined words.

27. What a shabby girl Namusisi is!

28. Our head prefect is a very humble boy.

For questions 29-30 re-write the following sentences giving one word for the underlined group of words.

29. The man who mends shoes has got an accident.

30. Their new headteacher is a good looking woman.

Sub-section II

For questions 31-50, rewrite the sentences as instructed in the brackets.

31. My father is very tall. My mother is very tall.

(Join the sentences beginning: Both-----)

32. we shall meet janet and hilda on saturday (Punctuate the sentences correctly)

33. P.4 children like English more than Maths. (Re-write using -----prefer-----)

34. Obia is fat. Odong is very fat. (Rewrite as one sentence using-----than-----)

35. Those mice have destroyed my cloth. (Rewrite the sentence beginning: That---)

36. All the P.4 children wrote interesting compositions yesterday.

(Re-write and end -----tomorrow.)

37. Muhwezi has head ache. Muhwezi will not go to school today.

(Join the sentences using -----because-----)

38. A buffalo is huge. A cow is huge. (Rewrite the sentence suing ----as-----as----)

39. Andrea is very clever. She can win the spelling competition.

(Re-write as one sentence using ----- so-----that-----)

40. That is the young lady. Her husband was shot at several times.

(Join the sentences using-----whose-----)

41. I met the president's convoy. I was going to the diary.

(Rewrite the sentences using----- when-----)

42. Our head teacher is a very polite man. (Begin: What-----!)

43. Evelyn sleeps on a bed. The bed is made of wood.

(Re-write as one sentence ending -----a wooden bed.)

44. There isn't any juice in the bottle. (Use-----some-----)

45. Joanita writes poorly. Joanita is very bright.

(Join the sentences using-----but-----)

46. The cyclist fell off his bicycle when he was rushing to town.

(Rewrite the sentence beginning: As-----)

47. Benard is using a ruler. His uncle bought the ruler for him.

(Join using -----which -----)

48. The children will enjoy the food. The teachers will enjoy the food.

(Re-write as one sentence beginning. Either-----)

49. I am eleven years old. (Write a suitable question for which this is the answer)

50. An apple a day------(Complete the saying correctly)

51. **Read the story carefully and answer the questions the that follow in full sentences.**

THE HARD –WORKING BOY

Lomillo Mark is a young boy from Kumi. He is in primary four at Kumi Junior School. His teacher is proud of him because he is well-behaved and hard – working. Lumillo comes from a poor family which can't provide all school requirements. However, because of his good behavior and hard work, his Maths teacher, Ms. Naluyange Carol, promised to support him with most of the school requirements. On Wednesday, she took him to the village market to shop for school which was to begin on Monday the following week.

At the market, he found there very many people. There were buyers and sellers who had different items. His teacher bought for him; a pair of shoes, uniform, a pen and a mathematical set. When they returned home, the teacher gave Lomillo some pocket money to use when at school. Lomillo and his parents thanked the teacher and Lomillo promised to continue with his good discipline and hard work.

Questions

1. Who is being talked about in the story?

2. In which school is Lomillo?

3. Why are Lomillo's teachers proud of him?

4. From which type of family does Lomillo Mark come?

5. Who promised to support Lomillo with the school requirements?

6. On which day did Ms. Naluyange take Mark to the market?

7. Write any two items they shopped at the market?

i) _____

ii) _____

8. Which people were at the market according to the passage?

9. Write "can't" in full.

52. **Study the notice below carefully and answer the questions that follow in full sentences.**

MUSIC SHOW!		MUSIC SHOW!	
PRESENTER:	Catherine Kusasira		
VENUE:	Club Ambiance		
DATE:	23 rd March, 2018		
TIME:	3:00pm – 6:00pm		
FEE:	Adults	:	shs 10, 000
	Children	:	shs 5,000
COME ONE!		COME ALL!	
MANAGEMENT:			
14th March, 2018			

Questions

a) What is the advertisement about?

b) Who will present the show?

c) Where is the show going to be staged?

d) When will the show take place?

e) Give another word for **venue**.

f) At what time will show start?

g) When was the advert written?

h) How much will an adult pay for the show?

i) How long will the show take?

j) Write **pm** in full:

53. The graph below showing the different kinds of food liked by children of Mother Majeri Primary School was pinned on one of the notice boards of the school. Study it carefully and answer questions in full sentences.

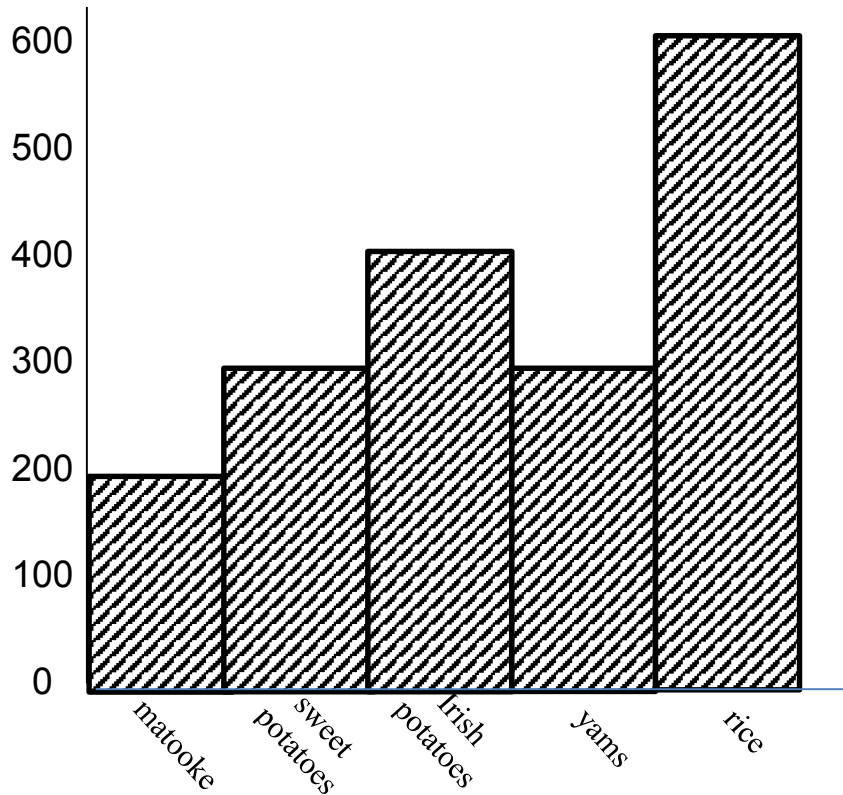

Questions

1) What is the graph about?

2) Which school is mentioned in the graph?

3) Which food stuff is liked by the least number of children?

4) How many children enjoy yams?

5) How many more children like sweet potatoes than matooke?

6) Where was the graph pinned?

7) Which food stuff is liked by most children?

8) How many food stuffs are shown on the graph?

9) Which food stuff is enjoyed by the same number of children?

10) Why do you think children enjoy rice most?

54. Use the words in the box below to complete the passage.

crops, thanked, farm, wanted, right, direction, farewell,
father, accompany, junction.

Last week, Joseph _____ to go to his father's farm. He did not know which _____ to take when he reached a _____ . He asked a passer-by to direct him to Wasswa's farm. The passer-by said, "The _____ is about fifty kilometers away". He asked Joseph to _____ him. They turned to the _____ of the junction and headed to Waswa's farm which was not far from the junction. Joseph _____ his guide and bid him _____ when they reached the farm.

Joseph was welcomed by his _____ who showed him different kinds of animals and _____ .



KINGS WAY PRIMARY SCHOOL

P. 4 RECESS REVISION 2020-(SET FIVE)

INTEGRATED SCIENCE

DURATION: 2 HOURS 15 MINUTES

Name stream.....

Read the following instructions carefully

1. This paper is made up of two Sections: A and B.
2. Section **A** has 40 questions (40 marks)
3. Section B has 15 questions (60 marks)
4. Attempt all questions. Answers to both sections must be written in the spaces provided.
5. All answers must be written in blue or black ballpoint pen or ink but not in pencil. All work done in pencil, except diagrams, will **NOT** be marked.
6. Crossing out of answers will lead to loss of marks.
7. Any handwriting that cannot be easily read may lead to loss of marks.

FOR EXAMINERS USE ONLY		
QN. NO.	MARK	SIGN
1-10		
11-20		
21-30		
31 – 40		
41 – 50		
51		
52		
53		
54		
55		
TOTAL		

SECTION A

1. Name any one item got from animal skins.

2. Give any one element of a clean home.

3. Write down any one sign of dehydration.

4. Why is it good to transplant seedlings in the evening?

5. Give any one example of a material used for mulching.

6. Why are petals of some flowers brightly coloured?

7. Write down any one importance of a shadow to man.

8. Why is breast milk regarded as the best food for babies?

9. Name the main body part of an insect where feelers are found.

10. State the element of weather that helps in pollination.

11. Name the part of the embryo that develops into the shoot system.

12. What is photosynthesis?

Use the structure below to answer questions 13 and 14.



13. Name the item for maintaining personal hygiene shown above.

14. How does the above item promote personal hygiene?

15. Give any one example of a domestic animal kept as a pet.

16. Write down any one importance of weeding maize.

17. State any one characteristic of living things.

18. How do trees benefit from birds?

19. How important are thorns to a cactus plant?

20. Give any one example of a wingless insect

21. Name any one type of weather that requires people to use umbrellas

22. Give any one role of the father in a family.

23. Write down any one importance of giving firstaid to casualties.

24. Mention the immunisable disease that affects bones.

25. Why do people boil drinking water?

26. Name any one harmful insect to man.

27. Which sense enables a boy to know the sweetness of tea?

28. How can we control soil erosion on the school compound?

Use the structure of a fish below to answer questions 30 and 31.

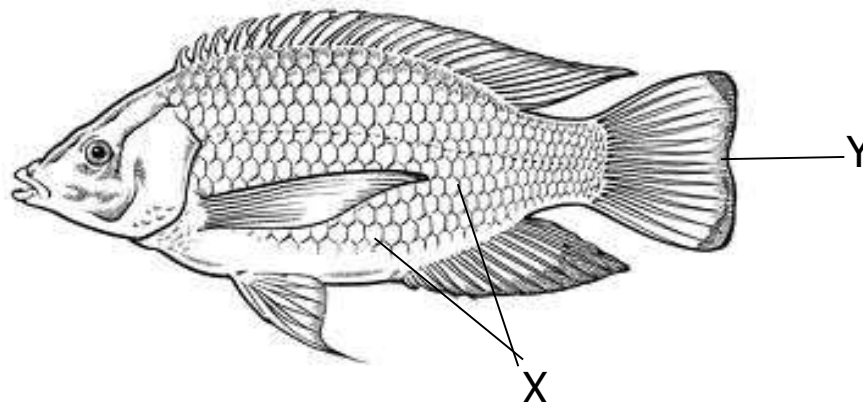

29. Name part labelled X.

30. What is the function of part marked Y to a fish?

31. Why do plants with weak stems climb others?

32. Name any one place where bacteria are found in the environment.

33. Where does fertilization take place in plants?

34. Name the vector that spreads the malaria parasites to people.

35. **In the space provided below, draw a leaf showing parallel venation.**

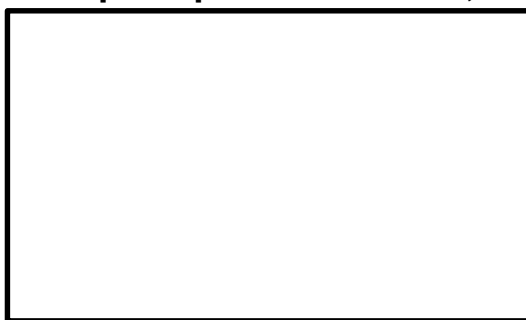

36. Give any one vegetable crop grown in the nursery bed.

37. Write down any one method of preserving food.

The diagram below is of weather instrument. Use it to answer questions 39 and 40.

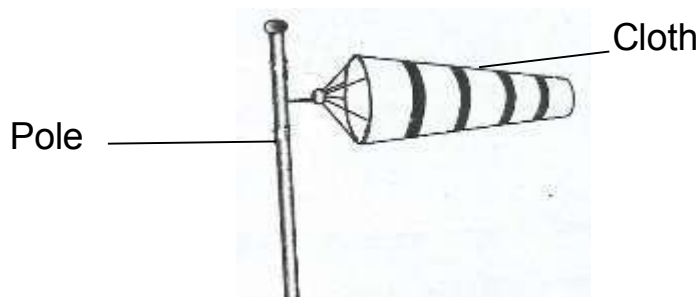

38. Name the instrument above.

39. How is the above instrument important in a weather station?

SECTION B (60 Marks)

40. a) What is personal hygiene?

b) Write down any two materials used to maintain oral hygiene

i) _____

ii) _____

c) Write down any one activity a P.4 boy does to keep his body clean.

41. a) Apart from shoot system state the other system of a flowering plant.

b) Give any two requirements needed by plants to make their own food.

i) _____

ii) _____

c) Which part of a seed develops into a shoot system?

42. a) Mention any two types of soil
 i) _____
 ii) _____
 b) Write down one importance of soil to insects.

 c) State any method of soil formation.

43. a) What causes AIDS?

 b) Write down any two ways through which AIDS is spread.
 i) _____
 ii) _____
 c) State any one effect of AIDS in the family.

44. Use the structure of an insect below to answer questions that follow:

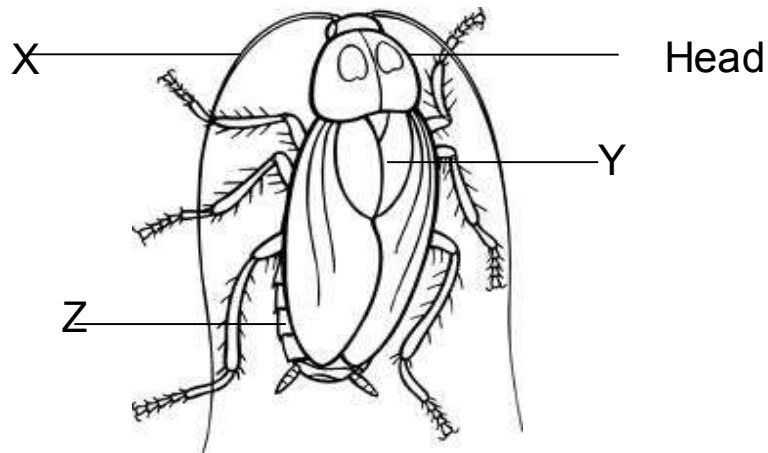

- a) Name the two main body parts marked Y and Z.
 i) Y _____
 ii) Z _____
 b) Write down the importance of part labelled X to an insect.

 c) Which part of an insect has the same function with lungs of a man?

45. a) What is a crop pest?

b) Give two examples of field pests.

i) _____

ii) _____

c) State any one sign of disease in plant leaves.

46. a) Give any two examples of perennial crops.

i) _____

ii) _____

b) State any one method of harvesting perennial crops.

c) Why do farmers prefer growing annual crops to perennial crops.

47. a) State any one use of electricity at home.

i) _____

ii) _____

b) Give two forms of energy produced by the sun.

i) _____

ii) _____

c) Suggest any one danger of electricity to the users.

48. a) Write O.R.S in full.

b) Apart from sugar, state the other two substances used for making O.R.S.

i) _____

ii) _____

c) Why is O.R.S given to a dehydrated person.

49. The diagram below shows a flower. Study and use it to answer the questions that follow.

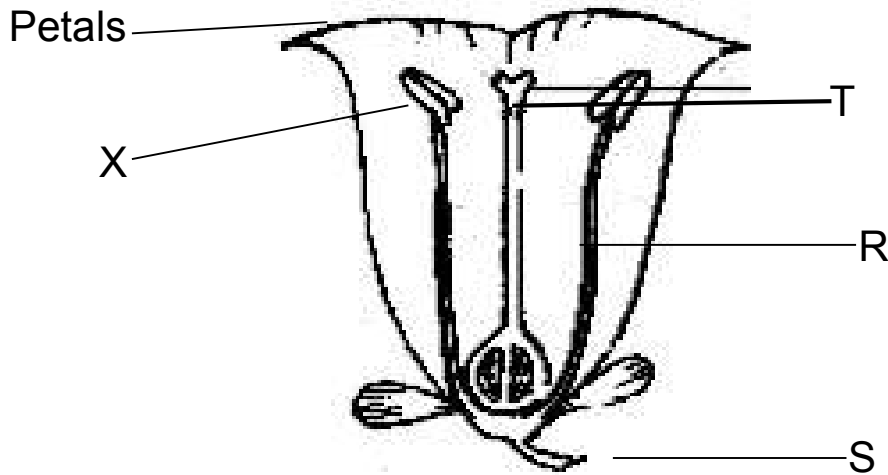

a) Name the parts labelled R and S.

i) R _____

ii) S _____

b) Give the function of the parts marked T and X.

i) T _____

ii) X _____

50. a) What is weather?

b) Mention any two elements of weather.

i) _____

ii) _____

c) Name the clouds that give us rain.

51. a) Name the main natural source of water.

b) Write down any two uses of water to man.

i) _____

ii) _____

c) Give any one disease associated with the use of water.

52. a) Mention any one vector that breeds in water

b) State any two ways of controlling diseases spread by house flies.

i) _____

ii) _____

c) How are houseflies able to spread of disease causing germs?

53. a) Apart from moisture, give any one other one condition needed for germination.

b) Write down any two seeds that undergo epigeal germination.

i) _____

ii) _____

c) How is moisture important in the process of germination.

54. Match the organisms with their mode of protection correctly.

A	B
Organisms	Protection
Snake	Hiding in a shell
Chameleon	By biting
Millipede	Changing colours
Snail	curling

i) Snake _____

ii) Chameleon _____

iii) Millipede _____

iv) Snail _____



KINGS WAY PRIMARY SCHOOL

P. 4 HOLIDAY REVISION 2020-(SET FIVE)

RELIGIOUS EDUCATION

DURATION : 2 HOURS

NameStream..... _____

Read the following instructions carefully

1. The paper is made up of two sections **A** and **B** with two parts (Christianity and Islamic)
2. Section **A** has **20** questions (**40 marks**)
3. Section **B** has 15 questions (**60 marks**)
4. Answer Either **Christianity** or **Islamic** questions but not **BOTH** in a question.
5. All answers must be written in the spaces provided.

SECTION A

1. Either: What did God create on the second day?

Or: What did Allah create on the second day?

2. Either: Give one way Christians talk to God.

Or: Give one way Muslims talk to Allah.

3. Either: Write down the first commandment in the Bible.

Or: Write down the first pillar in Islam.

4. Either: Mention any one Christian name for boys in your class.

Or: Mention anyone Islamic name for boys in your class.

5. Both: Name the son of Adam who was killed by the brother.

6. Either: Who leads prayers in a church?

Or: Who leads prayers in a mosque?

-
7. Either: Why did God choose Noah to build the Ark?
-
- Or: Why did Allah choose Nuhu to build the Ark?
-
8. Either: Who was the earthly father of Jesus?
-
- Or: Who was the father of Prophet Muhammad.
-
9. Either: Where did God promise to take all sinful Christians?
-
- Or: Where did Allah promise to take all sinful Muslims?
-
10. Either: What do Christians celebrate on Easter Sunday?
-
- Or: What do Muslims celebrate on Idd-Aduha.
-
11. Both: Mention any one example of sin committed in a community.
-
12. Both: What did God create in His own image
-
- Or: What did Allah create in His own image?
-
13. Either: In which town was Jesus buried?
-
- Or: In which town was Prophet Muhammad buried?
-
14. Either: How is River Jordan important in Christianity.
-
- Or: How does one become a Muslim?
-
15. Either: Give anyone symbol of a Christian family
-
- Or: Give anyone symbol of a Muslim family.
-
16. Either: Mention the first book in the Bible.
-

Or: _____
Name the Holy book for Muslims?

17. Either: State anyone importance of leaders in a church.

Or: State any one importance of leaders in a mosque.

18. Either: Why do Christians fast?

Or Why do Muslims fast?

19. Either: Who wrote the book of Exodus?

Or: Who receive the Tauret form Allah?

20. For Both: Mention any one domestic animal that God created.

SECTION B

21. Either: a) In which book in the Bible do we find the story of creation

b) Give any other three books in the Bible

i) _____

ii) _____

iii) _____

Or: Write down four Holy books in Islam.

i) _____

ii) _____

iii) _____

iv) _____

22. Either: **Match the days in List A with events in List B correctly.**

List A	List B
Good Friday	The day Jesus went back to heaven.
Holy Thursday	The birth of Jesus Christ.
Christmas day	The day Jesus was arrested.
Ascension day	The day Jesus died on the cross.

- a) Good Friday _____
- b) Holy Thursday _____
- c) Christmas day _____
- d) Ascension day _____

Or: **Match the words in List A with their meaning in list B correctly.**

List A	List B
Mecca	A place for sinful Muslims
Mt. Hira	A place of rest for faithful Muslims
Janah	A place where prophet Muhammad received the revelation of the Qu'ran
Jahanam	A place where prophet Muhammad was born.

- a) Mecca _____
- b) Mt. Hira _____
- c) Janah _____
- d) Jahanam _____

23. Either a) What is a sin?

- _____
- b) Give any three results of sin to people.
- i) _____
- ii) _____
- iii) _____

Or: a) What is a sin?

- _____
- b) Give any three results of sin to people.
- i) _____
- ii) _____
- iii) _____

24. Either : a) Give any two ways Christians show love to one another in a community.

- i) _____
- ii) _____
- b) Mention any two things that can break good relationship among people in a community.
- i) _____
- ii) _____

Or: a) Give any two ways Muslims show love to one another in the community.

i) _____

ii) _____

b) Mention any two things that can break good relationship among people in a community.

i) _____

ii) _____

25. Either: a) On which mountain did Moses receive the 10 commandments from God?

b) Write down any three of the ten commandments of God

i) _____

ii) _____

iii) _____

Or: Name any four pillars of Islam(Ibadat)

i) _____

ii) _____

iii) _____

iv) _____

26. **Both:** a) State any four good things a good P.4 child can do to a friend in class.

i) _____

ii) _____

iii) _____

iv) _____

27. Either: a) Name the three sons of Adam.

i) _____

ii) _____

iii) _____

b) Why did Cain kill Abel?

Or: a) Name the two sons of Adam and Hawa.

i) _____

ii) _____

b) Why did Qabeel kill Habeel?

c) _____
What punishment did Allah give Qabeel?

28. Either :a) Name any four animals God created to give man meat (food)

i) _____

ii) _____

iii) _____

iv) _____

Or: Name any four animals Allah created to give man meat(food).

i) _____

ii) _____

iii) _____

iv) _____

29. Either :Name the four body parts God gave you to use

i) _____

ii) _____

iii) _____

iv) _____

Or: Name the four body parts Allah gave you to use.

i) _____

ii) _____

iii) _____

iv) _____

30. Either: a) Give any four qualities of a good child of God/Allah.

i) _____

ii) _____

iii) _____

iv) _____

Or: Give any four qualities of a good child of Allah.

i) _____

ii) _____

iii) _____

iv) _____

31. Either: Name any four Apostles of Jesus Christ.

- i) _____
- ii) _____
- iii) _____
- iv) _____

Or: Name any four prophets of Allah.

- i) _____
- ii) _____
- iii) _____
- iv) _____

32. Either: Mention any four things Christians use in a church.

- i) _____
- ii) _____
- i) _____
- ii) _____

Or: Mention any four things Muslims use in a mosque.

- i) _____
- ii) _____
- iii) _____
- iv) _____

33. Either: Give any four groups of people that need help from others.

- i) _____
- ii) _____
- iv) _____
- v) _____

Or: a) Which pillar of Islam encourages Muslims to help others?

b) Mention any three items that Muslims take to the mosque inform of Zakat.

- i) _____
- ii) _____
- iii) _____

34. Either: a) Why did God create man last?

b) State any three ways man destroys God's creation.

i) _____

ii) _____

iii) _____

Or: a) Why did God create man last?

b) State any three ways man destroys Allah's creation.

i) _____

ii) _____

iii) _____

35. **FOR BOTH.**

a) Give any three items children can share at school

i) _____

ii) _____

iii) _____

b) How is sharing important to children at school?

END



KINGS WAY PRIMARY SCHOOL

P. 4 HOLIDAY REVISION 2020-(SET FIVE)

MATHEMATICS

DURATION : 2 HOURS 30 MINUTES

NameSTREAM.....

Read the following instructions carefully

1. This paper has **two** Sections: **A** and **B**.
2. Section **A** has 20 answer questions (40 marks)
3. Section **B** has 12 questions (60 marks)
4. Answer **ALL** questions. Answers to both sections must be written in the spaces provided.
5. All answers must be written using a blue or black ballpoint pen or ink. Diagrams should be drawn in pencil.
6. Unnecessary alteration of work may lead to loss of marks.
7. Any handwriting that cannot be easily read may lead to loss of marks.
8. Do not fill anything in the box indicated for examiner's use only.

FOR EXAMINERS USE ONLY		
QN. NO.	MARK	
1 - 10		
11 - 20		
21 - 22		
23 - 24		
25 - 26		
27 - 28		
29 - 30		
31 - 32		
TOTAL		

SECTION A (40 MARKS)

1. Subtract: $12 - 4$

2. Solve for M: $M + 3 = 10$

3. Change 900cm to metres

4. Find the next number in the sequence:
12, 10, 8, 6, _____, _____

5. Shade $Y \cap X$ in the Venn diagram below.

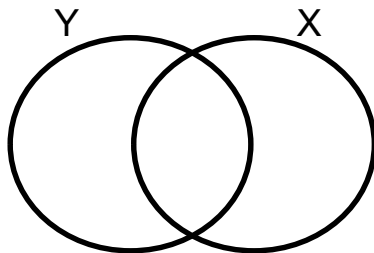

6. Write 325 in words

7. Shade $\frac{1}{2}$ of the figure below

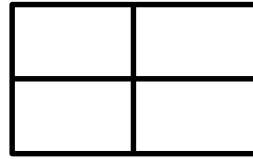

8. Draw a cylinder in the space below.

9. Show twenty minutes to eight O'clock on the clock face below

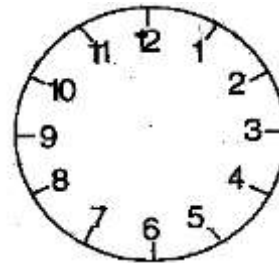

10. Add: $\begin{array}{r} \text{sh: } 4\ 5\ 0\ 0 \\ +\text{sh: } 5\ 6\ 0\ 0 \\ \hline \end{array}$

11. If  represent 5 balls. How many balls will be drawn to represent 20 balls?

12. Express 19 in Roman numerals

13. Workout 1 - $\frac{5}{9}$

14. Multiply : $\begin{array}{r} 32 \\ \times 4 \\ \hline \end{array}$

15. Collect like terms:
 $2x - y + 3x + 2y$

16. Change 5 kg to grams.

17. Draw the set symbol for equivalent sets.

18. Add:

Weeks	Days
3	5
+ 2	4

19. Expand 342 using values.

20. Share 28 mangoes among 4 pupils.

SECTION B (60 MARKS)

21. Give that, $A = \{ a, b, c, d, e, f \}$ and $B = \{ f, g, h, e, d \}$

a) Represent the above information on the venn diagram below. (3mks)

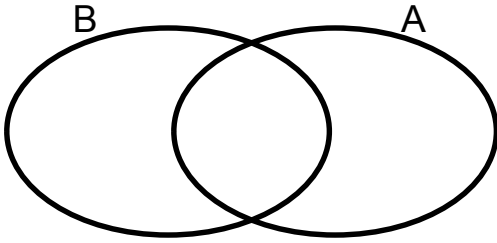

b) Find $n (A \cap B)$ (2mks)

22. Name the shapes below (1 mk@)

i)

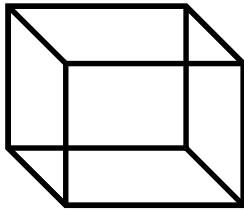

(ii)

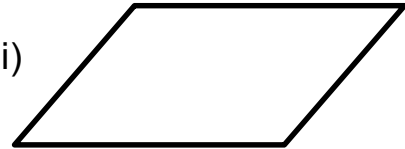

b) Draw the shapes below. (1mk @)

i) Triangle

ii) Trapezium

23. a) Work out the following : (2mks@)

i) $\frac{6}{9} + \frac{2}{9}$

ii) $\frac{3}{5} - \frac{2}{5}$

24. Use $>$, $<$ or $=$ to complete the statements below correctly (2mks @)

a) 2 weeks _____ 21 days

b) 3×4 _____ $4 + 3$

c) XXV _____ 25

d) A fifth _____ $\frac{1}{2}$

25. Study the table below and answer the questions that follow

Item	Price
Ruler	shs. 1,000
Pen	shs. 500
Book	shs. 1,500
Rubber	shs. 400

a) Find the total cost of all the four items (2mks)

b) Diana went to the shop with shs. 5000 and bought all the items, what was her change? (2mks)

c) Name the most expensive item. (1mk)

26. Find the missing number in the following (2mks@)

a) $\square - 5 = 3$

b) $\square + 4 = 4$

c) $\square \div 3 = 2$

27. Given the number 3852.

a) Expand the number using values (2mk)

b) Write the number in words. (1mk)

c) What number has been expanded to get
 $(2 \times 100) + (0 \times 10) + (4 \times 1)$ (2mks)

28. Joy is 10 years old. Peter is 5 years older than Joy.

a) How old is Peter? (2mks)

b) Find their total age? (2mks)

c) How old will Joy be after 4 years time (2mks)

29. a) Divide $2 \overline{) 263}$ (2mks)

b) Subtract: sh: 8,500
- sh: 6,400

30. Study the figure below and answer the questions that follow.

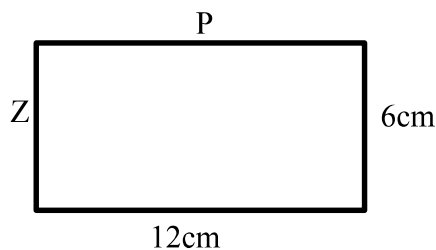

a) How many sides does the above figure have?

b) Find the value of

i) $P =$ _____ ii) $Z =$ _____

c) Find the perimeter of the above figure (2mks)

31. Use the graph below to answer the questions that follow.

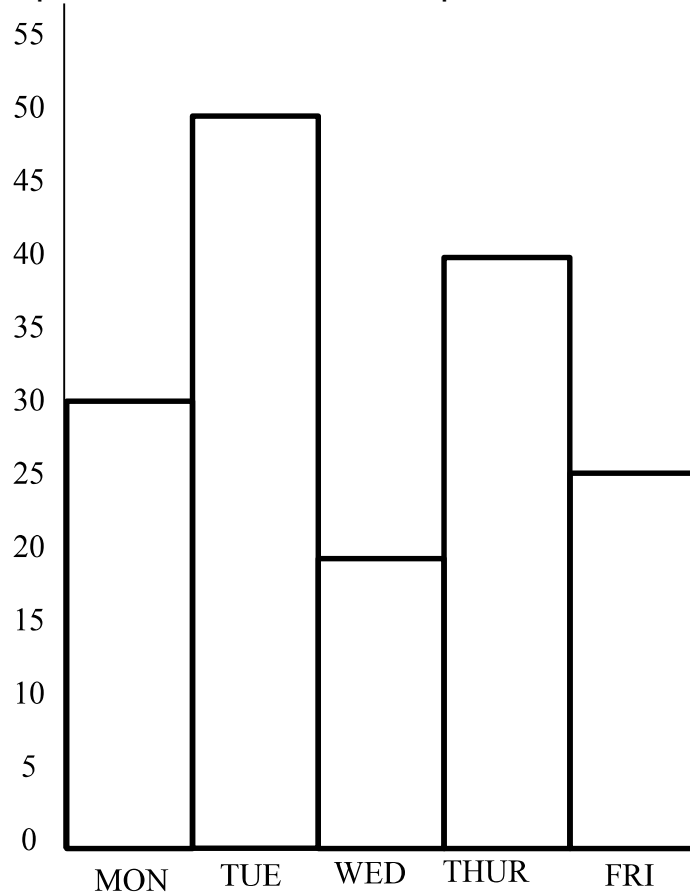

a) Which day of the week had the highest number of eggs collected? (1mk)

c) Which day had the least number of eggs collected? (1mk)

b) How many eggs were collected on Monday and Friday? (2mks)

d) How many eggs were collected in the five days (2mks)

32. a) Change 5 years to months (2mks)

b) Add: years months
 7 6
 + 2 8



KINGS WAY PRIMARY SCHOOL

P. 4 RECESS REVISION 2020-(SET FIVE)

SOCIAL STUDIES

DURATION: 2 HOURS 15 MINUTES

NameStream.....

Read the following instructions carefully

1. This paper has two sections: **A** and **B**.
2. Answer **all** questions. **All** answers to both sections **A** and **B** must be written in the spaces provided.
3. **All** answers must be written using a blue or black ball-point pen or fountain pen.
4. Unnecessary changes of work may lead to loss of marks.
5. Any handwriting that cannot easily be read may lead to loss of marks.
6. Do **not** fill anything in the boxes indicated "**For Examiners' Use Only**" and those inside the question paper.

FOR EXAMINERS' USE ONLY		
QN. NO.	MARK	EXRS' NO.
1-10		
11-20		
21-30		
31-40		
41-43		
44-46		
47-49		
50-52		
53-55		
TOTAL		

SECTION A

1. What is homestead?

2. Why do pupils put on school uniform?

3. How is the police important in our community?

4. Which school symbol encourages pupils to work hard?

5. Give any one role of a father at home.

6. Mention any one important place in our community.

7. What name is given to the special song of our school.?

8. State anyone type of a house in our community.

9. Write L.C in full.

10. Mention the important stadium near our school.

11. Why do people go to the market?

12. How is the dog important in our home?

13. What is culture?

14. State anyone importance of trees in our school compound.

15. Give any one basic need of a family.

16. Why do we need farmers in our community?

17. Draw a map of a table in the space provided below.



18. How do we keep our school compound clean?

19. Why do we need a zebra crossing on roads?

20. Give any one symbol of a clan?

21. Name any one raw material from the environment used for making crafts.

22. What is weather?

23. State any one cause of accidents at school.

24. Give any one component of the environment.

25. Mention any one tool used for keeping peace and security in our community.

26. Write down one group of people who violate children's rights.
-
27. In which direction does the compass needle always point when it is at rest?
-
28. How is a key important to a map reader?
-
29. Write K.C.C.A in full?
-
30. What name is given to a low land between two hills?
-
31. Name the pole on which the flag fly?
-
32. In which region of Uganda is our school found?
-
33. Who was the first Muganda?
-
34. Mention the biggest Ethnic group in our community.
-
35. What is the meaning of the road sign below?

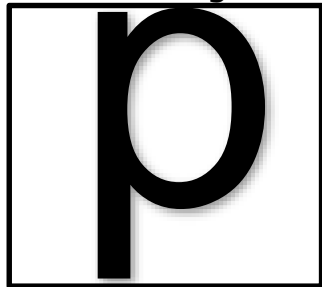

For questions 36-40, answer either Christianity or Islamic but not both on a number.

36. Either: Who created the universe?
-

Or: Who created the universe

37. Either: Why do Christians pray to God?

Or: Why do Muslims pray to Allah?

38. Either: How many people entered Noah's Ark?

Or: How many people entered Nuhu's Ark?

39. Either: Mention one thing God created to give use light during the day.

Or: Mention one thing Allah created to give us light during the day.

40. Either: How important is a Bible to Christians.

Or: How important is a Qu'ran to Muslims.

Section B (60 marks)

41. a) What is a map?

b) Mention any three qualities of a good map.

i) _____

ii) _____

iii) _____

42. a) State any two conditions of weather.

i) _____

ii) _____

b) Which activities do farmers carry out during the rainy season?

i) _____

ii) _____

43. a) Give the meaning of the term environment.

b) Mention any two human activities that destroy the environment.

i) _____

ii) _____

c) How are trees important to a farmer in our community?

44. a) What term is given to mean a sudden happening that causes an injury or death?

b) Name any two examples of accidents common at home

i) _____

ii) _____

c) Give any way of avoiding accidents at home.

45. Use the diagram below to answer the questions that follow.

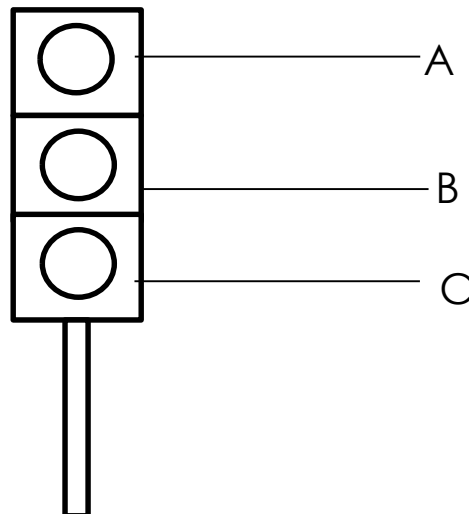

a) Name the colours marked on the diagram above.

A _____ B _____

C _____

b) Give the meaning of colour marked A to the road user.

46. a) In which municipality is our school found?

b) Mention any three important places in our municipality.

i) _____

ii) _____

ii) _____

47. a) What are physical features?

b) Give any three examples of drainage features.

i) _____

ii) _____

iii) _____

48. a) Give the direction of the sun in the morning.

b) A part from the position of the sun, give other three local ways of locating places

i) _____

ii) _____



iii) _____

49. a) What are basic needs?

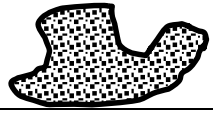

b) Mention any three examples of basic needs of man

- i) _____
- ii) _____
- iii) _____

50. Match symbols in list A with the meaning in List B correctly

List A	List B
	Permanent lake
	Permanent River
	A swamp
	Water fall

List A	List B

	_____
	_____
	_____

Questions 51 – 55 answer Either Christianity or Islam but not BOTH on a number

51. Either: a) Who is a leader?

b) Mention any three examples of church leaders

i) _____

ii) _____

iii) _____

Or: a) Who is a leader?

b) Mention any three examples of leaders in a mosque.

i) _____

ii) _____

iii) _____

52. Either:(a) What is a church?

b) Give two symbols of Christianity

i) _____

ii) _____

c) What should a Christian do after sinning.

Or: a) What is a mosque?

b) Give two symbols of Islam.

i) _____

ii) _____

c) What should a good Muslim do after sinning?

53. Either: a) How many days did God take to create the world?

b) Why did God create man?

i) _____

ii) _____

c) Who was the first woman to be created by God?

Or: a) How many days did Allah take to create the world?

b) Why did Allah create man.

i) _____

ii) _____

c) Who was the first woman to be created by Allah?

54. Either : a) How many apostles did Jesus have?

b) Write down any three apostles of Jesus.

i) _____

ii) _____

iii) _____

Or: a) Who is a caliph?

b) Write down any three caliphs of Prophet Muhammad.

i) _____

ii) _____

iii) _____

55. **Both:** a) State any two similarities between Christians and Muslims.

i) _____

ii) _____

b) Give any two differences between Christians and Muslims.

i) _____

ii) _____

END