



# KINGS WAY PRIMARY SCHOOL

## P. 5 RECESS REVISION 2020-(SET FOUR) MATHEMATICS

**TIME ALLOWED : 2 HOURS 30 MINUTES**

Name \_\_\_\_\_ Stream \_\_\_\_\_

**DO NOT OPEN THIS BOOKLET UNTIL YOU ARE TOLD TO DO SO.**

**Read the following instructions carefully**

1. This paper has two Sections: A and B.
2. Section A has 20 answer questions (40 marks)
3. Section B has 12 questions (60 marks)
4. Answer ALL questions. Answers to both sections must be written in the spaces provided.
5. All answers must be written using blue ink. Diagrams should be drawn in pencil.
6. Unnecessary alteration of work may lead to loss of marks.
7. Any handwriting that cannot be easily read may lead to loss of marks.
8. Do not fill anything in the box indicated for examiner's use only.

SECTION A: 40 MARKS

1. Multiply: 
$$\begin{array}{r} 13 \\ \times 3 \\ \hline \end{array}$$

2. Add: 
$$\frac{3}{11} + \frac{2}{11}$$

3. Write 2019 in words.

4. List down all the factors of 12.

5. Describe the shaded part in the Venn diagram below.

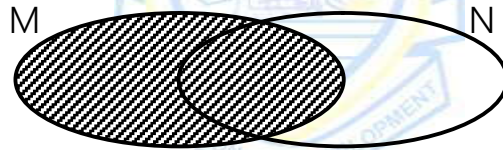

6. Find the missing number in the box.

$$4 \times \square = 24$$

7. Find the lowest common multiple of 3 and 5.

8. Name the set symbol below.



9. Share 65 oranges amongst 5 pupils.

10. What number has been expanded to give;  $(8 \times 1000) + (5 \times 100) + (2 \times 1)$  ?

11. Write XXVI in Hindu Arabic numerals.

12. Work out the total distance round the figure below.

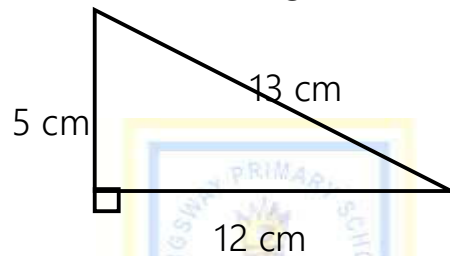

13. Add  $4 + 5$  using a number line below.



14. Express  $2\frac{3}{4}$  as an improper fraction.

15. The radius of a circle is 7 cm. Find its diameter.

16. Simplify:  $3a + 5c + 2a + c$ .

17. Kiyimba bought a shirt at sh. 7500 and later sold it at sh. 9000. Find his profit.

18. Name the shape below.

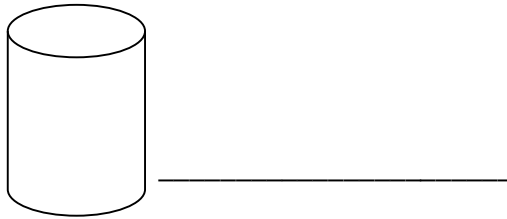

19. Draw the tallies to represent the number 23.



20. A motorist covered a distance of 1200 km on marram road and another 1400 km on tarmac road. Find the total distance covered by the motorist.

SECTION B: 60 MARKS

21. Study the given sets below and answer the questions that follow.

**Y = {cup, plate, cat} and Z = {shirt, dress, cat}.**

a) Set Y and set Z are \_\_\_\_\_ sets? (1 mark)

b) Find; (2 marks)

i)  $Y \cap Z =$  \_\_\_\_\_

ii)  $Y \cup Z =$  \_\_\_\_\_ (2marks)

22. Fill in the missing numbers in the figure below. (1 mark@)

|                   |   |       |       |       |       |
|-------------------|---|-------|-------|-------|-------|
| Number of hands   | 1 | _____ | 3     | _____ | 6     |
| Number of fingers | 5 | 10    | _____ | 20    | _____ |

23. Study the figure below and answer the questions that follow.

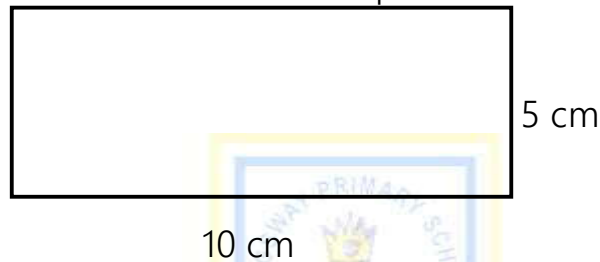

a) Name the figure above.

(2 mark)

\_\_\_\_\_

c) Find the area of the figure.

(2 marks)

24. **Use < or > or = to make the statement true.** (1 mark @)

a)  $3 + 8$  \_\_\_\_\_  $3 \times 8$

b) 2 weeks \_\_\_\_\_ 14 days

c)  $\frac{7}{9}$  \_\_\_\_\_  $\frac{3}{9}$

d) 1 kg of feathers \_\_\_\_\_ 1 kg of stones.

25.a) Subtract:  $\frac{6}{10} - \frac{4}{10}$

(2 marks)

b) Nalumansi ate  $\frac{1}{5}$  of a cake and Stella ate  $\frac{2}{5}$  of the cake. What fraction did the two girls eat altogether? (2 marks)

c) Shade  $\frac{3}{6}$  of the diagram below. (2 marks)



26.a) Work out:  $20 \times 4$  (2 marks)

$$\begin{array}{r} 20 \\ \times 4 \\ \hline \end{array}$$

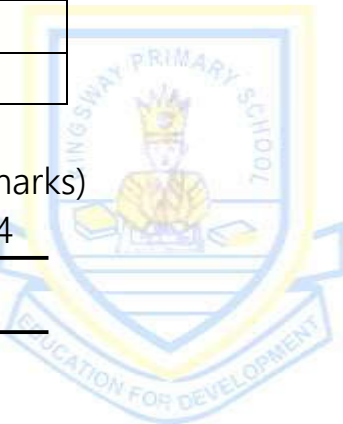

b) Subtract 80 from 190.

(2 marks)

c) Divide 844 by 4

(2 marks)

27. (1 mark @)

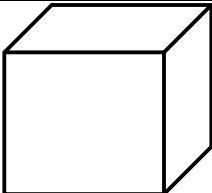
| <b>Name these shapes.</b>                                                           |                                                                                     | <b>Draw these shapes</b> |               |
|-------------------------------------------------------------------------------------|-------------------------------------------------------------------------------------|--------------------------|---------------|
|  |  | <i>Cylinder</i>          | <i>Square</i> |
|                                                                                     |                                                                                     |                          |               |

28. **If  $n = 5$  and  $w = 6$** , find the value of; (2 marks @)

a)  $n + w$

b)  $n \times w$

29.a) Write "Two thousand, forty four" in figures.

(2 marks)

b) Expand 4532 using values

(2 marks)



c) Round off 87 to the nearest tens.

(2 marks)

30.a) How many days are there in 6 weeks?

(2 marks)





32. Study the division machine below and find the missing numbers. (4 marks)

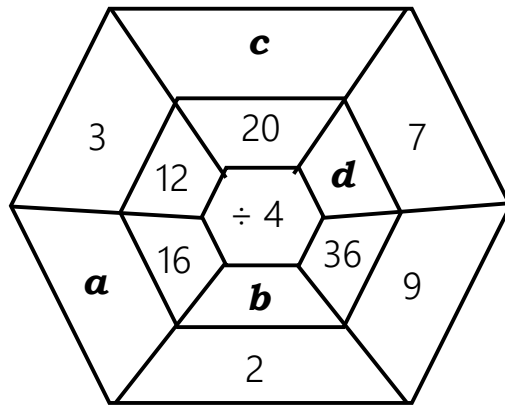

a= \_\_\_\_\_

b= \_\_\_\_\_

c= \_\_\_\_\_

d= \_\_\_\_\_



END



# KINGS WAY PRIMARY SCHOOL

P. 5 RECESS REVISION 2020-(SET FOUR)

**INTEGRATED SCIENCE**

**DURATION : 2 HOURS 15 MINUTES**

Name \_\_\_\_\_ Stream \_\_\_\_\_

**DO NOT OPEN THIS BOOKLET UNTIL YOU ARE TOLD TO DO SO.**

**Read the following instructions carefully.**

1. This paper is made up of two Sections: A and B.
2. Answers to both sections must be written in the spaces provided in full sentences.
3. Section A has 40 questions (40 marks)
4. Section B has 15 questions (60 marks)
5. Attempt all questions. All answers to both sections A and B must be written in the spaces provided.
6. All answers must be written in blue or black ballpoint pen or ink but not in pencil. All work done in pencil, except diagrams, will **NOT** be marked.
7. Crossing out of answers will lead to loss of marks.
8. Any handwriting that cannot be easily read may lead to loss of marks.
9. Wrong spelling will lead to loss of marks.

## FOR EXAMINERS USE ONLY

| QN. NO.      | MARK | <u>SIGN</u> |
|--------------|------|-------------|
| 1 - 10       |      |             |
| 11 - 20      |      |             |
| 21 - 30      |      |             |
| 31 - 40      |      |             |
| 41 - 43      |      |             |
| 44 - 46      |      |             |
| 47 - 49      |      |             |
| 50 - 52      |      |             |
| 53 - 55      |      |             |
| <b>TOTAL</b> |      |             |

## SECTION A

1. Name the main natural source of heat of light in the environment.  
.....
2. How do we call the process by which green plants make their own food?  
.....
3. Single out one example of an edible insect.  
.....
4. State one reason for giving first aid.  
.....
5. Give any one component of soil.  
.....
6. State any one source of food.  
.....
7. Why is a goat regarded as a domestic animal?  
.....
8. Give one reason why P. 5 children eat food.  
.....
9. Suggest one reason why left over food should be covered.  
.....

**The diagram shows a property of air.**

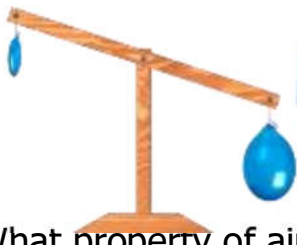

10. What property of air shown above?  
.....
11. Why is it a good habit to wash hands before eating food?  
.....
12. Give one use of wind to people.  
.....
13. Mention one pest that effects stored crops.  
.....
14. Which elements of weather causes floods?  
.....
15. Name an immunisable disease which cripples children.  
.....
16. Cite any one product obtained from cows.  
.....
17. Mention any one example of a communicable disease.  
.....

18. Why is a maize grain regarded as a fruit?

19. **Draw the shadow.**



20. Point out any way farmers can control weeds in the garden.

21. Suggest one reason why animals move from one place to another.

22. What is a balanced diet?

**The diagram shows a type of leaf variation.**



23. Name the type of variation shown above.

24. Suggest one plant with the above type of leaf variation.

25. Why do farmers weed their crops?

26. Name the type of family that comprises of the husband, wife and biological children.

27. Mention one disease that attacks rabbits.

28. How do we preserve fish in the community?

29. Mention the mineral salt used to harden bones and teeth.

**Study the diagram below and answer questions 30 and 31.**

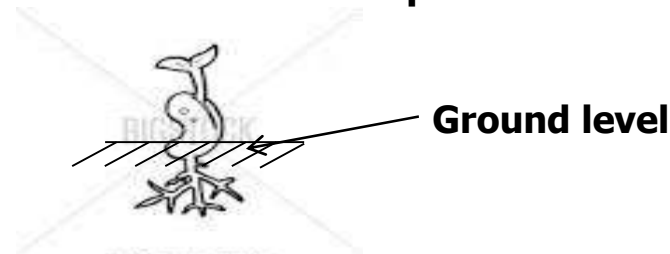

30. What type of germination is shown above?  
.....
31. Name one crop which undergoes the above type of germination.  
.....
32. Why do we iron beddings?  
.....
33. Mention the condition in which a child lacks enough water in the body.  
.....
34. State one use of water at home.  
.....
35. Name the habitat of fish.  
.....
36. State any one way of controlling soil erosion.  
.....
37. Mention any one way of keeping the body clean.  
.....

**38. Identify the type of tooth shown below.**

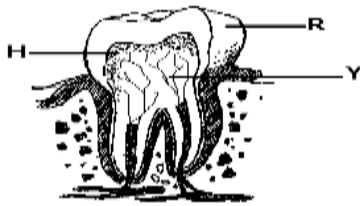

39. State one reason why a Stevenson screen is painted.  
.....
40. What do we call a sudden happening that can cause harm or death?  
.....

**SECTION B (60 MARKS)**

41. (a) What do we call plants that do not bear flowers?  
.....
- (b) State two things used to prepare ORs.
- (i).....
- (ii) .....
- (c) How do the above plants mentioned in (a) above reproduce?  
.....
42. (a) Write ORS in full.  
.....
- (b) Mention any two things used to prepare ORS.
- i) .....

- ii) .....
- c) Why is a dehydrated child given ORS?

43. a) Which type of soil is best for crop growing?

b) Mention any two types of soil.

- i) .....
- ii) .....
- c) Give one item made out of clay soil.

**44. The diagram below is of a bean seed. Use it to answer questions that follow.**

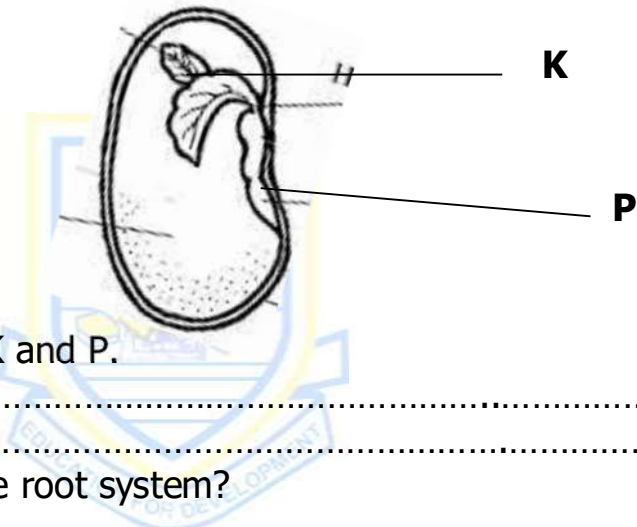

a) Name the parts marked K and P.

- i) K.....
- ii) P.....

b) Which part grows into the root system?

c) Give one condition necessary for seeds to germinate.

45. (a) Give two components of the environment.

- i) .....
- ii) .....

(b) How useful are plants to man in the environment?

- (i).....
- (ii) .....
- (c) Mention any one man-made change that destroys the environment.

46(a) What is personal hygiene?

.....

.....

(b) State two activities which can be done to promote personal hygiene.

- i) .....
- ii) .....

d) Write down one item used to keep the teeth clean.

**47. The following are garden tools. Use them to answer questions that follow.**

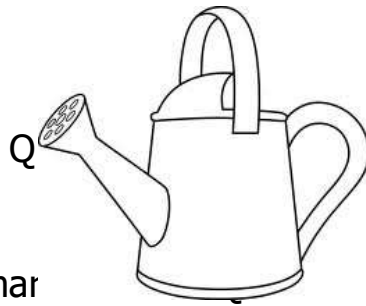

(a) Name the garden tools marked

(i) P.....

(ii) Q.....

b) How useful are the garden tools above to farmers

(i) P.....

(ii) Q.....

48. (a) What name is given to a female rabbit?

.....

b) State two reasons why people keep rabbits.

i) .....

ii) .....

(c) Write down one exotic breed of rabbits.

49. Give one example of each of the following types of crops.

a) Cereal crops.....

b) Leguminous crops.....

c) Root crops.....

d) Vegetable crops.....

**50. Match the items in A with those in B correctly.**

**Group A**

- Housefly
- Female anopheles mosquito
- Fresh water Snail
- Blackfly

**Group B**

- River blindness
- Bilharzias
- Malaria
- Cholera

**Group A**

- Housefly
- Female anopheles mosquito
- Fresh water Snail
- Blackfly

**Group B**

- .....
- .....
- .....
- .....

51. a) What term refers to organisms that destroy crops?

.....

b) List down two examples of the organisms you have named in (a) above

i) .....

ii) .....

c) State one way in which a crop farmer can control the organisms above.

i) .....

ii) .....

52 a) List down two examples of domestic birds.

(i) ..... ii) .....

b) Give two reasons why farmers keep domestic birds.

i) .....

ii) .....

**53. The diagram below shows the lifecycle of an insect. Use it to answer questions that follow.**

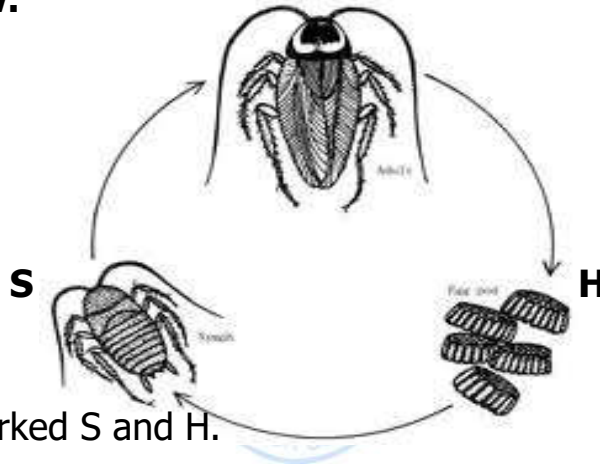

a) Name the stages marked S and H.

i) S .....

ii) H .....

b) What type of lifecycle is shown above?

.....

c) State one way of controlling cockroaches at home.

.....

54. a) What is mulching?

.....

b) Name one material used for mulching?

.....

c) State two reasons why farmers mulch their gardens?

(i) .....



(ii) .....  
55. a) How do we call the state of the atmosphere recorded for a short period of time?

.....  
b) Mention any two elements of weather.

(i) .....

(ii) .....

c) Name the types of weather needed during winnowing?  
.....

**END**





# KINGS WAY PRIMARY SCHOOL

P. 5 RECESS REVISION 2020-(SET FOUR)

**SOCIAL STUDIES & R.E**

**DURATION : 2 HOURS 15 MINUTES**

Name \_\_\_\_\_ Stream \_\_\_\_\_

**DO NOT OPEN THIS BOOKLET UNTIL YOU ARE TOLD TO DO SO.**

Read the following instructions carefully.

1. This paper is made up of two Sections: A and B.
2. Answers to both sections must be written in the spaces provided in full sentences.
3. Section A has 40 questions (40 marks)
4. Section B has 15 questions (60 marks)
5. Attempt all questions. All answers to both sections A and B must be written in the spaces provided.
6. All answers must be written in blue or black ballpoint pen or ink but not in pencil. All work done in pencil, except diagrams, will **NOT** be marked.
7. Crossing out of answers will lead to loss of marks.
8. Any handwriting that cannot be easily read may lead to loss of marks.
9. Wrong spelling will lead to loss of marks.

| FOR EXAMINERS USE ONLY |      |             |
|------------------------|------|-------------|
| QN. NO.                | MARK | <u>SIGN</u> |
| 1 - 10                 |      |             |
| 11 - 20                |      |             |
| 21 - 30                |      |             |
| 31 - 40                |      |             |
| 41 - 43                |      |             |
| 44 - 46                |      |             |
| 47 - 49                |      |             |
| 50 - 52                |      |             |
| 53 - 55                |      |             |
| <b>TOTAL</b>           |      |             |

**SECTION A (40 MARKS)**

**1.** Mention any one important place in our district.

.....

**2.** Name the lake where we get salt.

.....

**3.** How do we call the collection of many trees growing together?

.....

**4.** Where do people keep their money safely?

.....

**5.** What do we call a person who heads a village local council?

.....

**6.** Write the importance of a heading on a map.

.....

**7.** Why should schools have prefects?

.....

**8.** Which line of latitude is marked  $0^{\circ}$  on a map?

.....

**9.** State any one use of a natural forest to man.

.....

**10.** Draw the map symbol of a hill in the space provided.



**11.** Identify one activity done by farmers in the dry season.

.....

**12.** Give one use of wind to man.

.....

**13.** State one reason why school children wear school uniform.

.....

**14.** How are accidents dangerous to people?

.....

**15.** Mention any one way of reducing road accidents.

.....

**16.** What do we call a low land between two hills or mountains?

.....

17. Write one member of a nuclear family.  
.....
18. Which type of soil is good for a potter?  
.....
19. What term do we use to mean the plant cover of an area?  
.....
20. State one reason why people plant grass in their school compound.  
.....
21. Give any one example of cash crop.  
.....
22. Mention any one way early man got his food.  
.....
23. Name one group of people who need a compass in their daily work.  
.....
24. State any one quality of a good leader.  
.....
25. Mention one man-made lake that is found in the central region of Uganda.  
.....
26. Give one responsibility of a child in the community.  
.....
27. Identify the highest peak on mountain Elgon.  
.....
28. State any one example of the children's rights.  
.....
29. Identify any one local way of locating places on the map.  
.....
30. Mention one product got from animal skins and hides.  
.....
31. Who was the bad brother of Nambi?  
.....
32. Write **BOU** in full.  
.....
33. Why is air transport used by few people in Uganda?  
.....
34. Why is Kalangala called an island district.  
.....

35. Write one example of a social activity that is practiced in your community.

.....

**For Questions 36-40, Answer Either Christianity Or Islamic But Not Both.**

36. **Either:** Name the Holy book for Christians.

.....

**Or:** Name the Holy book Moslems.

.....

37. **Either:** What did God create in His image?

.....

**Or:** What did Allah create in His Image?

.....

38. **Either:** Name the holy city where Jesus was born.

.....

**Or:** Name the holy city where Prophet Mohammed was born.

.....

39. **Either:** What is the fasting period of Christians called?

.....

**Or:** In which months do Muslims fast.

.....

40. **Either:** Name any one title of a Christian leader in a church.

.....

**Or:** Name any one title of a Moslem leader in a mosque.

.....

**SECTION B (60 MARKS)**

41. a) What type of vegetation covers most parts of Uganda?

.....

b) State one importance of vegetation to wild animals.

.....

c) Mention two ways in which people have destroyed the environment.

i) .....

ii).....

42. a) Which important discovery helped early man to live a settled life?

.....

b) **Draw the tools that were used by early man.**

|              |              |
|--------------|--------------|
|              |              |
| <b>bolas</b> | <b>spear</b> |

c) Identify any one example of food that early man ate.  
.....

**43.** a) Name the means of transport used in each of the named type of transport.

- a) Water transport .....
- (b) Air transport .....
- c) Road transport .....
- d) Name the animal used for transport in hilly areas.  
.....

**44.** (a) How are televisions useful to people?  
.....

(b) Mention any two television stations in Uganda.

- (i) .....
- (ii) .....

(c) Why are there no television sets in some homes?  
.....

**45.** a) Mention any one role of a family head.  
.....

b) Identify any two basic needs of a family.

- i) .....
- ii) .....

c) Give one reason why some families do not get basic needs.  
.....

**46.** a) Give any two examples of religious leaders.

- i).....
- ii).....

b) State any one way how people become leaders.  
.....

c) Identify any one quality of a good leader.

.....

**47. Study the map below and answer questions that follow.**

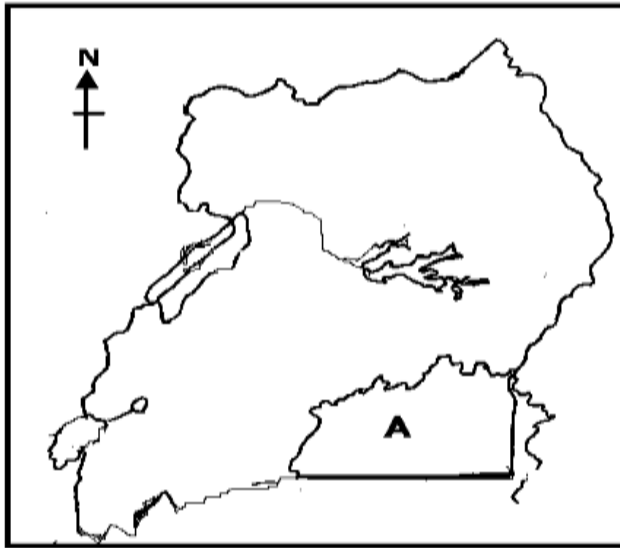

(a) Name the lake marked **A**.

.....

(b) Name the lake marked **A**.

.....

(c) Which element of a map is shown on the map above?

.....

(d) Give one use of lake marked **A**.

.....

**48. Write the following abbreviations in full.**

a) **UPE** .....

b) **Dr.** .....

c) **RDC** .....

d) **DEO** .....

**49** a) Name the two types of Mountains.

i) .....

ii) .....

b) Identify any two problems faced by people who live around mountains.

i) .....

ii) .....

**50.** a) Mention any two economic activities carried out by people in your district.

i) .....

ii) .....

b) Identify any one district in Uganda that are crossed by the Equator.

.....

c) In which region in Uganda is Kampala located?  
.....

**For Questions 51-55, Answer Either Christianity Or Islamic But Not Both.**

**51** **Either** a) Mention the first people to be created by God.

i).....

ii).....

b) How did the above people disobey God?  
.....

c) Identify the immediate punishment that was given to the above people for disobeying God.  
.....

**Or:** a) Mention the first two people Allah created.

i).....

ii).....

b) How did the above people disobey Allah?  
.....

c) Identify the immediate punishment that was given to the above people for disobeying Allah.  
.....

**52. Either:** a) Who killed Abel?  
.....

b). Name the son of Adam who replaced Abel.  
.....

c). State the reason why Abel was killed by his brother.  
.....

d) Who was the father of Abel?  
.....

**Or:** Mention any two holy cities in Islam.

i) .....

ii) .....

b) Why are the following people important in Islam?

i) Imam .....

ii) Muezzins .....

**53. Either:** a) State the events that took place below.



i) Mountain Sinai

.....

ii) River Jordan

.....

iii) Cana .....

iv) Bethlehem

.....

**Or:** Explain the following words according to Islamic faith.

(i) Hejira .....

(ii) Hijja .....

(iii) Haji .....

(iv) Hajjat .....

**54. Either:** a) Explain the term Gospel.

.....

.....

b) Outline any three Gospel books in the Bible.

i).....

ii).....

iii).....

**Or** a) Give one reason why Moslems pray.

.....

b) Write any three prayers conducted by Muslims daily.

i).....

ii).....

iii).....

**55. FOR ALL PUPILS**

a) Mention any one example of a good decision a P.4 child can make.

.....

b) Identify any one person in the Bible who made a good decision.

.....

c) State any one example of a bad decision.

.....

d) Give one effect or result of a bad decision.

.....

**END**



# KINGS WAY PRIMARY SCHOOL

P. 5 RECESS REVISION 2020-(SET FOUR)

**ENGLISH**

**DURATION : 2 HOURS 15 MINUTES**

Name .....

Stream .....

**DO NOT OPEN THIS BOOKLET UNTIL YOU ARE TOLD TO DO SO.**

**Read the following instructions carefully.**

1. This paper is made up of two Sections: A and B.
2. Answers to both sections must be written in the spaces provided in full sentences.
3. Section A has 50 questions (50 marks)
4. Section B has 5 questions (50 marks)
5. Attempt all questions. All answers to both sections A and B must be written in the spaces provided.
6. All answers must be written in blue or black ballpoint pen or ink but not in pencil. All work done in pencil, except diagrams, will **NOT** be marked.
7. Crossing out of answers will lead to loss of marks.
8. Any handwriting that cannot be easily read may lead to loss of marks.
9. Wrong spelling will lead to loss of marks.

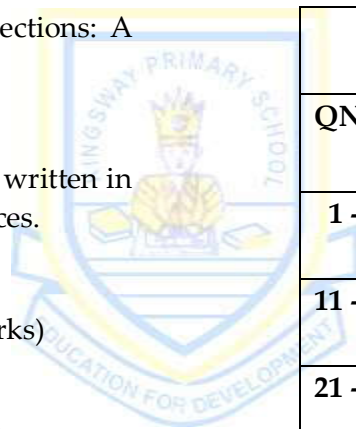

| FOR EXAMINERS USE ONLY |      |             |
|------------------------|------|-------------|
| QN. NO.                | MARK | <u>SIGN</u> |
| 1 - 10                 |      |             |
| 11 - 20                |      |             |
| 21 - 30                |      |             |
| 31 - 40                |      |             |
| 41 - 43                |      |             |
| 44 - 46                |      |             |
| 47 - 49                |      |             |
| 50- 52                 |      |             |
| 53 - 55                |      |             |
| <b>TOTAL</b>           |      |             |

**SECTION A**

(Questions 1 to 50 carry one mark each)

**Sub-Section I**

**In questions 1 to 5, fill the blank spaces with a suitable word or group of words.**

1. ....a cow and a goat are domestic animals.
2. The hen lays an.....every day.
3. January is the.....month of the year.
4. My teacher borrowed a novel.....the librarian.
5. How .....sugar did Mother put in the tea?

**In questions 6 and 15, complete the following sentences using the correct form of the word in brackets.**

6. A friend of .....is sick with malaria. (our)
7. Children in my class write ..... (good)
8. We go .....every week. (swim)
9. The girl is .....than the woman. (kind)
10. The .....are marking books in the staff room. (teach)
11. John .....wrote the letter yesterday. (quiet)
12. Two ..... were playing football in the field. (child)
13. The baby fell down and .....bitterly. (cry)
14. The family goes to the garden.....a week. (two)
15. ....is an interesting sport. (run)

**In questions 16 and 17, arrange the given words in alphabetical order.**

16. good, goes, goat, gone

.....

17. axe, six, van, ten

.....

**In questions 18 and 19, use the words in sentences to show that you know the difference in their meaning.**

18. our .....
19. hour .....

**In questions 20 to 22, write the short forms in full.**

20. Won't .....
21. Sat. ....
22. Dr. ....

**In questions 23 to 25, rewrite the sentences giving the opposite forms of the underlined words.**

23. The tree is in front of the building.  
.....
24. The girls arrived after the lesson.  
.....
25. The road to Masaka is narrow.  
.....

**In questions 26 and 28, give a single word for the underlined group of words.**

26. My father's brother is a very caring man.  
.....
27. I will visit my cousin in the last month of the year.  
.....
28. Our school bus was taken to a place where vehicles are repaired.  
.....

**In questions 29 and 30, arrange the given words to form meaningful sentences.**

29. story books likes reading Peter.  
.....
30. you old How are?  
.....

**Sub-Section II**

From **31** to **50**, re-write the sentences as instructed in brackets.

31. Tendo likes dancing more than singing. (Use; .....who.....)  
.....
32. Mary is the girl. She kept the teacher's bag. (Join using: .....who.....)  
.....
33. It was very cold. The pupils didn't go for games.(use:...because...)  
.....

34. She went to the supermarket. She did not buy anything.  
(Begin: Although.....)  
.....  
.....
35. Martha is very clever. She cannot fail that question.  
(Use: .....so.....that.....)  
.....  
.....
36. The thief stole my goat. (Begin: My goat .....)  
.....  
.....
37. Daddy likes reading books more than watching news.  
(Rewrite the sentence using: .....prefers.....)  
.....  
.....
38. An elephant is a wild animal.  
(Rewrite the sentence ending: .....animals.)  
.....
39. There isn't any soup in the pan.  
(Rewrite the sentence using: .....some.....)  
.....
40. Mary was doing homework. Sarah was cooking food. (Rewrite the sentences  
beginning: While..... )  
.....  
.....
41. It is bad to pocket while greeting.  
(Rewrite the sentence ending.....bad.)  
.....
42. That is the girl. That girl's sweater got lost.  
(Join the sentence using.....Whose .....)  
.....  
.....
43. Nambuya is a polite girl. Nambusi is also a polite boy.  
(Begin: Both .....)  
.....  
.....

44. I am going to the market.  
(Rewrite a suitable questions for the response)  
.....
45. Makumbi lent a pen to Mukalazi.  
(Join the sentence using; .....borrowed.....)  
.....
46. I read a story book. It was so good.  
(Join using.....which.....)  
.....
47. Nancy is heavy. Joan is heavy (Join the sentences using:.....as.....as.....)  
.....
48. A hare is a very wise animal. (Rewrite beginning: What .....!)  
.....
49. Musa is very young. He cannot cross a busy road.  
(Rewrite using:.....enough.....)  
.....  
.....
50. We went to bed after saying prayers. (Begin: After.....)  
.....

**SECTION B (50 MARKS)**

51. Read the passage below and correctly answers in full sentences, the questions that follow.

There are many things our teachers stop us from doing but because they interest us, we continue doing them. Among those things is walking while twisting our backs and walking on top of walk-way pavements at school.

One day, Nalumansi, a girl with tiny eyes in Primary Four got a problem. As her usual habit, she was slopping on top of the pavement towards the jack fruit junction, Nalumansi slid off the pavement and fell down very badly.

Her dress swung in the air and showed her other clothes. She couldn't avoid diving into dirty flowing water which dirtied her uniform. Good enough, she didn't get injuries but her friends couldn't help laughing at her helplessly. She became the talk. She was saddened by such a shame. Nalumansi promised to never walk on the pavement as her teachers always said. We should always take elders' words seriously.

## Questions

1. What is the passage about?

.....  
.....

2. Who fell down according to the passage?

.....  
.....

3. In which class is Nalumansi?

.....  
.....

4. Where was Nalumansi going?

.....  
.....

5. What were the children stopped from doing?

.....  
.....

6. Why did Nalumansi's friends laugh at her?

.....  
.....

7. What saddened Nalumansi?

.....  
.....

8. What happened to Nalumansi?

.....  
.....

9. Which lesson do we learn from the passage?

.....  
.....

10. Suggest a suitable title to the passage.

.....  
.....

52. Sophie went with her father, Mr. Kalungi for shopping at Acacia Mall last week.

| No | Item     | Quantity    | Price (shs) |
|----|----------|-------------|-------------|
| 1. | Books    | 2           | 1000/=      |
| 2. | Pens     | 1 dozen     | 1000/=      |
| 3. | Sugar    | 2 kilograms | 6000/=      |
| 4. | Biscuits | 4 packets   | 2000/=      |
| 5. | Soap     | 3 bars      | 10000/=     |
| 6. | Juice    | 1 bottle    | 500/=       |

## Questions

1. Whose shopping list is this?  
.....

2. When did they go for shopping?  
.....

3. Where did they go for shopping? .....

4. How many items are on Sophie's list?  
.....

5. How many bars of soap did she buy?  
.....

6. Who is Sophie's father?  
.....

7. How much did she pay for a bottle of juice?  
.....  
.....

8. How many books did she buy?  
.....

9. Write in full.

(i) doz. ....

(ii) shs .....

10. What day follows Friday?  
.....

53. Read the poem and answer the questions about it in full sentences.

Where is my pen?  
I want to write a letter  
To my class teacher  
And apologize to him  
For breaking class rules

I will tell him.  
That fighting in class  
Was not good  
And I will never repeat it  
So that he forgives me

I want him to forgive me  
And allow me back to class  
I am missing lessons  
And I am tired of home  
I want to come back to school.



**Questions**

1. What is poet looking for?  
.....
2. Why does he need a pen?  
.....  
.....
3. Where is the writer?  
.....
4. How many stanzas does the poem have?  
.....
5. To whom is he going to write a letter?  
.....
6. What is the writer missing according to the third stanza?  
.....  
.....
7. Why does the writer want to apologise?  
.....  
.....
8. Who wrote the poem above?  
.....
9. What does the writer want to tell the teacher?  
.....  
.....
10. Why does the writer want to go back to school?  
.....  
.....

54. Match the words in list **A** with their meanings in list **B**.

- A**
- Triangular
  - In front of
  - Borrow
  - Bank
  - Midday
  - Library
  - Spectators
  - Umpire
  - Costumes
  
  - Ballot paper

- B**
- a large room where books are kept.
  - time around 12:00 noon
  - a piece of paper on which you tick your vote
  - in the shape of a triangle
  - ahead of
  - judge in the netball game
  - special clothes worn by actors and actresses
  - an organization which keeps our money
  - getting something from someone for use and return it afterwards.
  - people watching a game or sport.

Triangular .....  
 In front of .....  
 Borrow .....  
 Bank .....  
 Midday .....  
 Library .....  
 Spectators .....  
 Umpire .....  
 Costumes .....  
 Ballot paper .....

**55. Complete the letter below sensibly.**

Valley Primary School .....  
 P.O. .... 29679,  
 Kampala.  
 26th September, 2017

.....Sarah,

How are you doing? How is your family?

I am..... to inform you that my .....party will be at Serena Hotel on 30<sup>th</sup> Sept 2017.

My ..... have organized and bought many things such as drinks, eats and music. Uncle George has bought for me many ..... for my birth .....

Please, come with your brother John.

I ..... forward to seeing you that day.

..... friend,

**Jane**

**END**