



KINGS WAY PRIMARY SCHOOL

P. 7 RECESS REVISION 2020-(SET THREE)

ENGLISH

Time allowed 2 hours and 15 minutes

NAME: _____

INDEX NUMBER

--	--	--	--	--	--	--	--	--

Signature: _____

District _____

EIMS Number: _____

EXAMINER'S USE ONLY

A	
B	
TOTAL	

Read the following instructions carefully:

1. This paper is made up of section A and B.
2. Section A, Sub section I, has 30 questions carrying 30 marks and Sub section II has 20 questions carrying 20 marks.
Section B has 5 questions, each carrying 10 marks.
3. Answer ALL questions. All answers to both section A and B must be written in the spaces provided.
4. All answers must be written in blue ink.
5. Any handwriting that cannot easily be read will lead to loss of marks.
6. Unnecessary alteration of work may lead to loss of marks.
7. Show all the necessary side work in pencil.

<u>PARENT'S COMMENT</u>	<u>SIGNATURE</u>

SECTION A (50 marks

Sub-section I (30 marks)

In questions 1 – 5, use the correct word to fill the gaps.

1. He seemed undecided _____ or not to write a letter.
2. The mid – term examinations have been _____ to next week.
3. We have slept in the same hotel _____ the last three weeks.
4. This question doesn't require much thinking, _____?
5. Do you know _____ icing sugar looks like?

In questions 6 – 15, use the correct form of the words given in brackets to complete the sentence.

6. I met Nsangi _____ some letters to the Head teacher's office. (carry)
7. Mr. Mukasa has supervised _____ thrice this term. (she)
8. Did you remember to put a _____ on your letter? (conclude)
9. You must buy an antenna if you don't live in _____ areas. (mountain)
10. We all got _____ from the bursar after paying for the trip. (receive)
11. He has _____ on your shoe unintentionally. (spit)
12. The company has got _____ into trouble over the new tax. (self)
13. Young children should be treated in a _____ way. (mother)

14. The more the news editor explained the point to the journalist, the _____ he understood. (little)
15. The debate between Kabojja Junior School and Nakasero Primary school ended _____. (peace)

For questions 16 – 18, rewrite the sentence giving another word for the underlined word (s)

16. All the passengers had tied their seat belts.

17. I wonder why she edited my article in a hurry.

18. The passer – by stopped and watched the fight between the waiter and the security guard.

For questions 19 and 20, rewrite the sentence giving the opposite of what is underlined.

19. It is legal to continue teaching candidates after their briefing.

20. His nephew came back from holidays last week.

For questions 21 and 22, use each of the words in a sentence to show that you know the difference in their meaning.

21. peace

22. piece

For questions 23 – 24 , arrange the given words in alphabetical order.

23. dearer, date, dearest, deer

24. spanner, tyre, speed, spare

For questions 25 and 26 write the plural form of the given words.

25. tablecloth

26. tsetse fly

In questions 27 – 28, rearrange the given words to form a sensible sentence.

27. need, our, What, to, we, examination, is, prepare, the.

28. post, Nairobi, you, letter, Did, my, to?

In question 29 and 30, write the full form of the given abbreviation.

29. Div.

30. PS

Sub - section II

In questions 31 to 50, rewrite the sentence as instructed in brackets.

31. Kityo wrote a very brief letter of application. (Rewrite the sentences and end:.....!)

32. We started a magazine project. We wanted to earn a living.
(Rewrite and join the sentences using:...so as.....)

33. The candidates will finish their homework on Sunday.
(Rewrite the sentence using:....looking forward.....)

34. If you don't mix the ingredients properly, I will not allow you to knead the dough. (Rewrite using:.....or else.....)

35. The farmer ran to the gate to welcome the veterinarian immediately she arrived.
(Rewrite the sentence beginning: No sooner)

36. The customer said, "Waiter, may I look at the menu, please?"
(Rewrite the sentence using:....requested.....)

37. A pair of scissors is used for cutting cloth. A pair of scissors is used for cutting threads. (Join the sentences using:....not only.....)

38. It is a long way from my home to the bakery.
(Rewrite the sentence using:.....far.....)

39. The carpenter made tables. They were brown. They were three. They were large. They were beautiful. (Join the sentences without using a conjunction.)

40. My cousin enjoyed watching television more than listening to folk stories.
(Rewrite the sentence using:.....prefer.....)

41. Mr. Kituntu taught us official letter writing. Mr. Kituntu taught us friendly letter writing. (Rewrite and join the sentences using, 'besides'.)

42. The traffic police officer has sensitised the motorists about driving carefully. The motorists still drive recklessly. (Join the sentences beginning: Despite.....)

43. There was some meat at the butcher's. (Rewrite the sentence using:...hardly.....)

44. The brown cake is mine. The brown cake is on the table. (Rewrite and join the sentences using.....which.....)

45. The primary seven candidates have flown to Dubai for their vacation. My cousin has flown to Dubai for her vacation. (Rewrite and join the sentences using:...and so.....)

46. We should not hate our teachers. (Rewrite the sentence and use:...ought.....)

47. Your letters are very tinny. The examiner cannot read them.

(Join the sentences using:too.....to.....)

-
48. We learn new words every time we use a dictionary.
(Rewrite the sentence beginning: Whenever.....)

-
49. Farmers will plant cassava if it rains. (Rewrite the sentence
using:....would.....)

-
50. I may register better performance in this mid – term one examination.
(Rewrite the sentence using:....likely.....)

Section B

51. **Read the passage carefully and answer the questions about it in full sentences. It was compiled by Namusoke Catherine.**

Our school was the first one to break up for end of year holidays last year, 2018. Schools were meant to begin holidays officially on 05/12/2018. However, due to certain problems such as lack of funds and our teachers' early going to mark P.L.E., we were forced to cut the term short by one week. Our headmaster, Mr. Nsamba Francis, asked all teachers to prepare our report cards quickly and see us off the school premises in the afternoon of 29th November, 2018. All pupils in the dormitory were very excited to hear this information. The matrons told us to begin collecting our property. "Check and see whether you have all the things you brought at the beginning of the term," they said.

The teacher on duty, Mr. Balimwikungu Henry, ordered the timekeeper to ring the bell for assembly. All our teachers addressed us and wished us a merry Christmas. Then we ran to our respective classes and waited

for our class teachers to give us our reports. Since my dad had left me with money for transport the day he came for visiting, I boarded a motorcycle from Kikajja Primary School to my home village Bukoloto, Kayunga District. I was very happy to reach home safely.

No sooner had I reached home than Mummy and Daddy asked for my report card. I was eager to give it to them since I had been promoted to Primary Seven. I was the fifth in the class of one hundred sixty pupils. They congratulated me on my performance, and it was Joy throughout the two – month holiday. I kept my mind off studies for the first month of the holiday, so as to help Father with garden work. After the first month of the holiday, Dad permitted me to visit my aunt Ritah, in Wakiso District. It was a short visit of one week when I came back, Dad took my school fees to Centenary Bank, Kayunga for banking.

Taking fees to the bank reminded me that the holiday was coming to an end. Reading books commenced because it was time to go back to school. In a nutshell, my holiday was interesting since I was always on good terms with my parents.

Questions

- (a) Who wrote the story above?

- (b) When did the writer break up for holidays?

- (c) Why did the writer’s school break up for holidays earlier than expected?

- (d) Why were the children in the dormitory excited?

(e) How did the writer travel to her home village?

(f) According to the passage, to which school does the writer go?

(g) How long was the writer's holiday?

(h) Where does the writer's aunt live?

(i) What made the writer enjoy her holidays?

(j) Suggest a suitable title for the passage.

52. **The sentences below are in a wrong order. Rearrange them correctly to form a sensible story.**

- (a) After we had completed eating, the waitress brought us the bill.
- (b) We studied it carefully and later we both made orders.
- (c) While we were at the table, a waitress welcomed us and gave us a menu.
- (d) Two weeks ago, Father and I had very sweet moments for the first time.
- (e) My father decided to thank me by taking me for a dinner at Hotel Mamerito, Kireka.
- (f) Finally, my father paid the bill and we went back home very happy.
- (g) From the parking yard, we moved towards the hotel balcony and then sat at a table.
- (h) The sweet moments began when I performed excellently in my beginning of term one examination.
- (i) On reaching there, Father parked his vehicle in the parking yard.
- (j) The waitress served us with delicious dishes we had ordered, and we really enjoyed the meal.

At times, there is disappointment
When the feast isn't delicious
Because of inadequate ingredients and failure to
Follow the recipe
But with persistence as my weapon
I end up a wonderful baker.

(KIBETE DAVID)

Questions

(a) What is being talked about in the poem?

(b) By whom was the poem written?

(c) Which stanza talks about baking?

(d) How many occupations are there in the poem?

(e) Why don't trainees excel in the first stanza?

(f) How many stanzas does the poem have?

(g) Who do you think is the speaker in the last stanza?

(h) Which other word can be used in place of the following words in the poem?

(i) inadequate

(ii) satisfaction

(i) Give the poem a suitable title.

54. **Read the information below carefully and answer the questions about it in full sentences.**

P.L.E. RESULTS SHEET
UGANDA NATIONAL EXAMINATIONS BOARD
PRIMARY LEAVING EXAMINATION
RESULTS FOR 2019
PAGE 5237
SCHOOL: 02278 MUSANA UMEA PRIMARY SCHOOL
DISTRICT: NJALA

INDEX NO	CANDIDATE'S NAME	M/F	ENG	MTC	SST	SCI	AGG	DIV
001	Adong Jemimah	F	2	3	2	1	8	1
002	Asio Belindah	F	1	2	1	1	5	1
003	Baliddawa Jospheh	M	2	2	5	4	13	2
004	Bujolijo Obedi	M	3	2	3	2	10	1
005	Gabigogo Sadik	M	1	2	2	2	7	1
006	Kabaleba Moses	M	1	1	1	1	4	1
007	Nakidole Sarah	F	1	2	2	5	10	1
008	Ndiwalana Sula	M	1	3	3	6	14	2
009	Ntondo Dauda	M	1	1	3	1	6	1
010	Nziza Norah	F	1	3	2	3	9	1
011	Odong Fahad	M	2	2	2	6	12	1
012	Opolot Musa	M	2	3	3	7	15	2
013	Zawedde Tracy	F	1	3	3	9	16	2

DIV 1	DIV 2	DIV 3	DIV 4	DIV U	DIV X
09	03	01	—	—	—

Questions

- (a) What is the information about?

(b) For which school are the above results?

(c) How many boys sat for the examination?

(d) Who was the best candidate in the school?

(e) Why do you think Tracy got F9 in Science?

(f) In which district is the above school?

(g) According to the information, how many candidates sat for PLE in the above school?

(h) Which candidates scored the same aggregate?

(i) How many second grades did the above school get?

(j) Which subject was best done that year?



KINGS WAY PRIMARY SCHOOL

P. 7 RECESS REVISION 2020-(SET THREE)

MATHEMATICS

Time: 2 hours 30 minutes

INDEX NUMBER

--	--	--	--	--	--	--	--	--

NAME: _____

Signature: _____

USE ONLY

District _____

Date _____

FOR EXAMINER'S

A	
B	
TOTAL	

Read the following instructions carefully:

30. This paper is made up of section A and B.
31. Section A has 20 short answer questions (40 marks).
3. Section B has 12 questions (60 marks).
4. All answers to both section A and B must be written in the spaces provided.
5. All answers must be written in blue ink and diagrams should be drawn in pencil.
6. Any handwriting that cannot easily be read will lead to loss of marks.
7. Unnecessary alteration of work may lead to loss of marks.
8. No calculators are allowed in the examination room.

PARENT'S COMMENT

SIGNATURE

SECTION A:(40 Marks)

1. Work out: $48 \div 4 =$

2. Write 62,002 in words.

3. Mukasa scored the following marks in a series of tests; 7, 5, 3, 1, 6,9, 0.
What was the range of his scores?

4. In the Venn diagram below, shade $(A \cup B)'$.

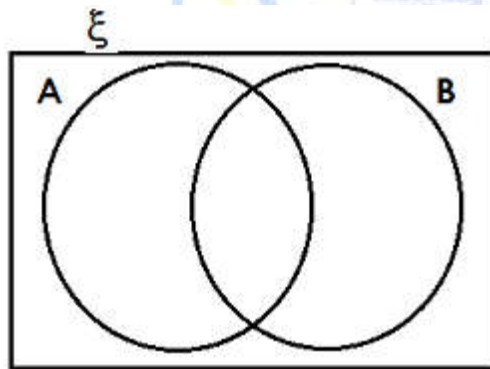

5. Using a ruler, a pencil and a pair of compasses only, bisect the angle given below

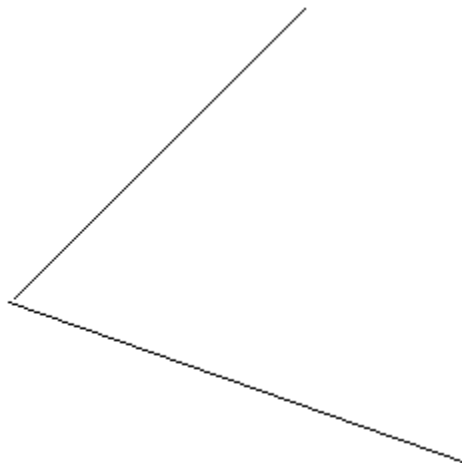

6. Find the next number in the sequence: 2 , 6 , 3 , 9 , 6 , 18 ,
_____.

7. Express $\frac{3}{8}$ as a percentage.

8. Find the value of $3^3 - 5^0$

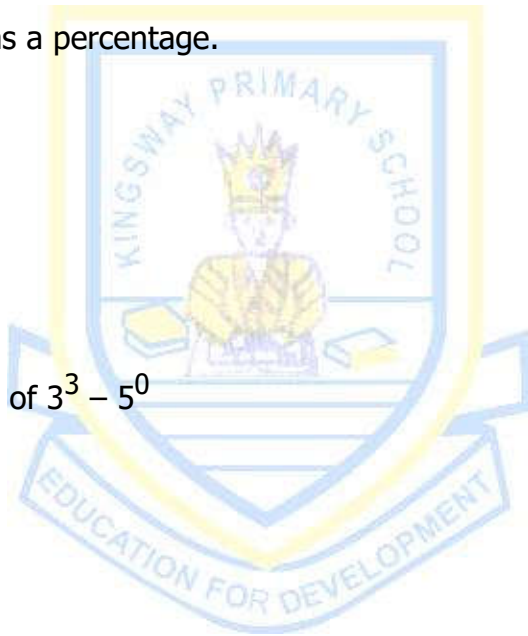

9. Round off 4.354 to the nearest hundred.

10. Change 3020g to Kg.

11. The exchange rate for pound sterling at Dembe Forex Bureau is Ugsh. 4850.
Opio had £120, how much money did he get?

12. Solve: $2y + 3 = 15$

13. Work out: $\frac{6}{7} \div \frac{3}{14}$

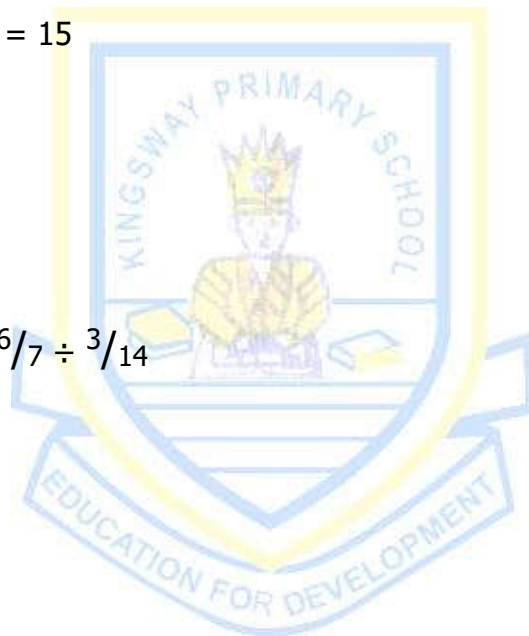

14. Fill in the missing number.

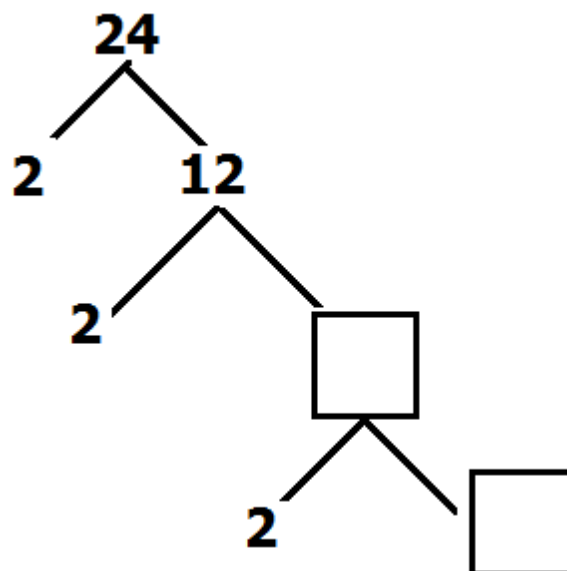

15. Write MCM in Hindu Arabic numerals.

16. Solve: $x + 4 = 2$ (finite 5)

17. Given that $a = 4$, $b = 6$ and $c = -3$, find the value of $\frac{a^2b}{c}$

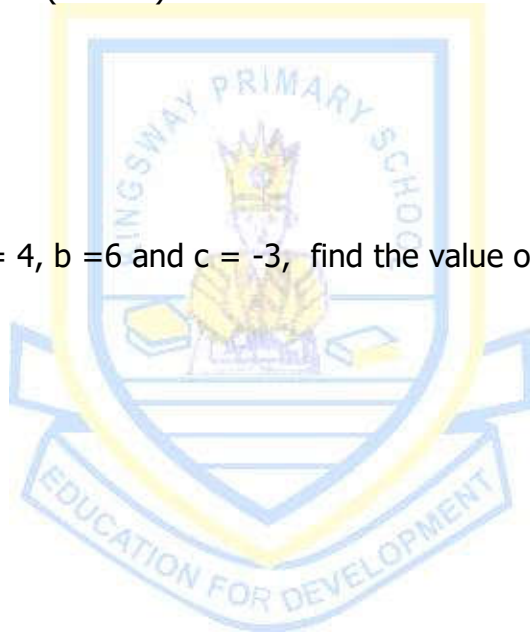

18. In a bag, there are 6 yellow pencils, 5 blue pencils and 9 green pencils. If a pencil is picked at random, what is the probability that it is yellow?

19. A mathematics lesson started at 8:25am and ended at 9:15am. How long was the lesson?

20. Calculate the circumference of a circle of radius 14cm. (take $\pi = \frac{22}{7}$)

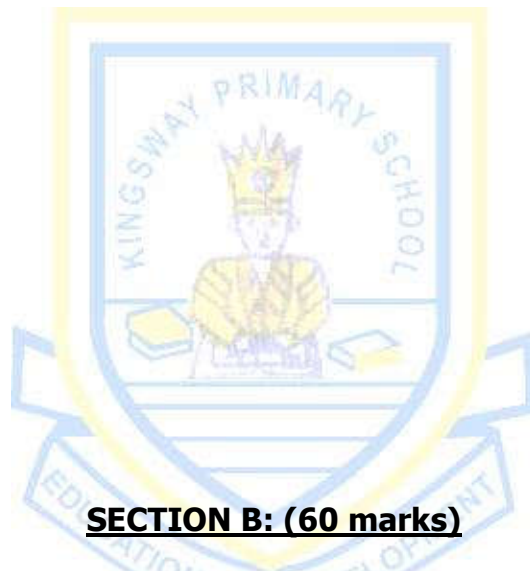

21. At a party attended by 40 children, 22 took Coke (C), y took Fanta (F) only, 13 took both types of soda. 7 took none of the two drinks.

(a) Complete the Venn diagram below. (2 marks)

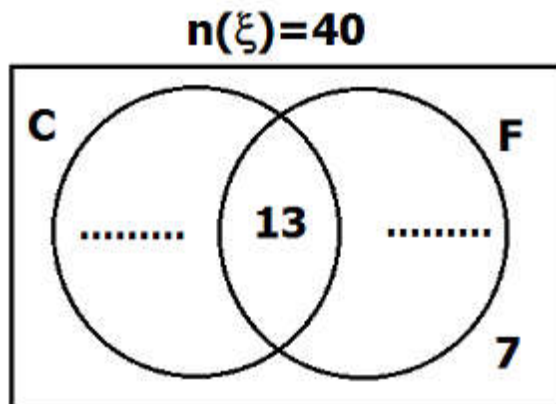

(b) What is the value of y ? (2 marks)

(c) How many children took fanta? (2 marks)

22(a) What is the quotient of the place value of 7 and the value of 5 in 697, 805? (3 marks)

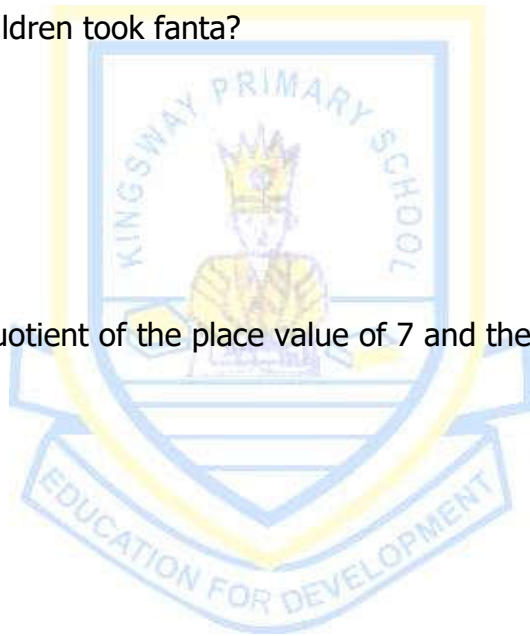

(b) Work out: $110_{\text{two}} \times 11_{\text{two}}$. (2 marks)

23. The table below shows Ms. Akello's shopping bill.

Item	Quantity	Unit cost	Total cost
Meat	2kg	Sh. 12000	Sh. _____
Rice	_____ kg	Sh. 4800	Sh. 7200
Salt	3kg	Sh. _____	Sh. 5400
Total Expenditure			Sh. _____

- (a) Complete the table.
(4 marks)

- (b) If she had sh. 50000, find her change.
mark)

(1



- 24(a) Using a ruler, a pencil and a pair of compasses only, construct a triangle PQR in which $PQ = 7\text{cm}$, $PR = 6.5\text{cm}$ and angle $QPR = 60^\circ$.
(4 marks)

- (b) Measure angle PQR.
(1 mark)

25. **The figure below shows a rectangular water tank.**

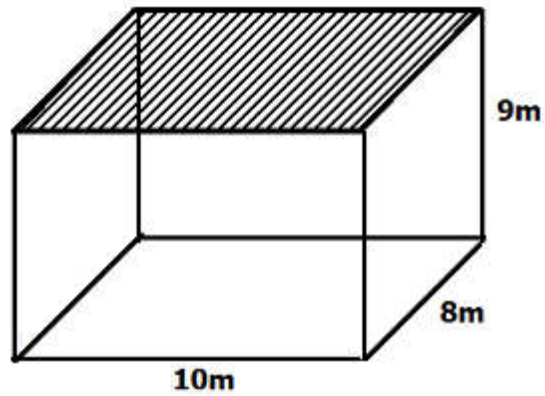

- (a) Calculate
marks)

(2

- (b) Find the area of the shaded part.
marks)

(2

26. **The Venn diagram below shows the prime factorisation of 30 and X.**

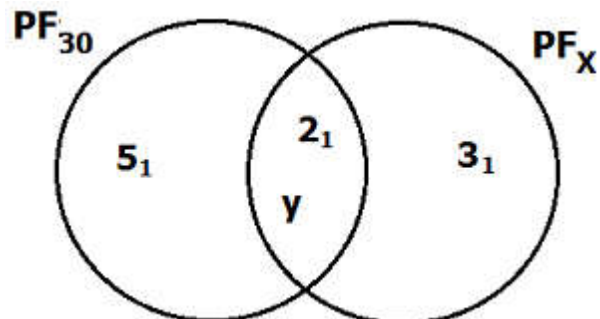

(a) Work out the value of **y**. (2 marks)

(b) What is the lowest common multiple of 30 and x? (2 marks)

27(a) Work out: $3\frac{1}{8} \div 3\frac{3}{4} \times 1\frac{4}{5}$ (3 marks)

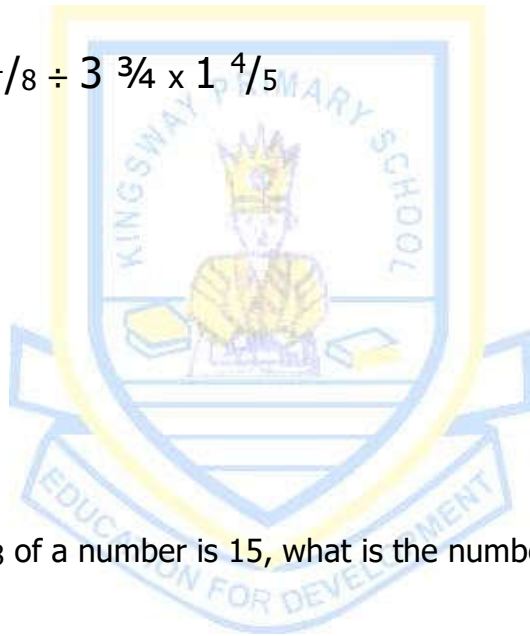

(b) Given that $\frac{3}{8}$ of a number is 15, what is the number? (2 marks)

28. Tom driving at 80km per hour took $2\frac{1}{2}$ hours from town P to town Q. He then continued to town R in 2 hours at 89km per hour.

(a) Find the distance from town P to town R. (3 marks)

- (b) Calculate his average speed from town P to town R. (2 marks)

29. The perimeter of the rectangle below is 68cm.

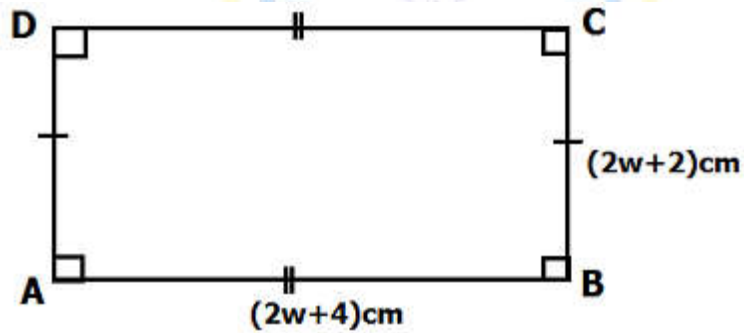

- (a) Work out the value of w . (2 marks)

- (b) Calculate the area of the rectangle.
marks)

(3

30. Jamil is 7 years older than Annet. In 10 years' time, the total of their ages will be 49 years. How old is each of them now?

(5 marks)



31. The figure below is an isosceles triangle LMN in which $LM = LN$.

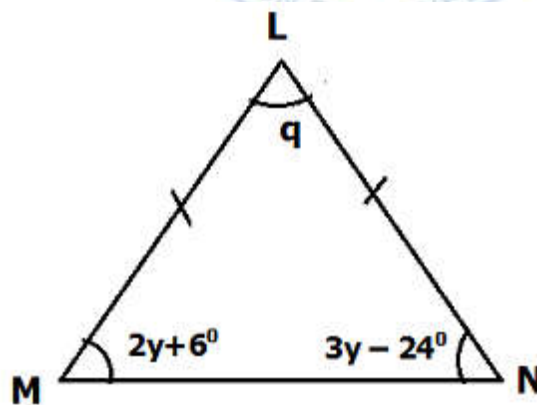

- (a) Work out the value of y .
(2 marks)

(b) Find the size of angle q ? **(3 marks)**

32. **The table below shows age of children in a village.**

Age in years	No. of children	Total age
4	3	12
6	4
7	42
.....	4	36
10	3	30

(a) Complete the table. **(3 marks)**

(b) How many children are in the village? **(1 mark)**

(c) Calculate the mean age. **(2 marks)**



KINGS WAY PRIMARY SCHOOL

P. 7 RECESS REVISION 2020-(SET THREE)

Social Studies with Religious Education

Time allowed: 2 hours and 15 minutes

INDEX NUMBER

--	--	--	--	--	--	--	--	--

NAME: _____

Signature: _____

District _____

Date _____

EXAMINER'S USE ONLY

A	
B	
TOTAL	

Read the following instructions carefully:

32. The paper is made up of section A and B.
33. Section A has 40 short answer questions (40 marks).
3. Section B has 15 questions (60 answers).
4. Answer ALL questions. All answers to both section A and B must be written in the spaces provided.
5. All answers must be written in blue ink.
6. Any handwriting that cannot easily be read will lead to loss of marks.
7. Unnecessary alteration of work may lead to loss of marks.
8. Show all the necessary side work in pencil.

<u>PARENT'S COMMENT</u>	<u>SIGNATURE</u>

Section A.

1. Name the weather condition necessary for weeding.

2. Mention one member state of the East African Community in southern hemisphere.

3. Give one importance of a post office in an area.

4. State any one advantage of traditional means of transport over modern means.

5. Give any one factor that attracts most wild animals to live in Savannah regions.

6. Name the water body that is found in the North of Africa.

7. State any one way in which culture is practiced in our society.

8. Give one duty of health workers in our communities.

9. State any one way in which the legislature helps the judiciary to carry out its roles.

10. **Name the physical feature represented below.**

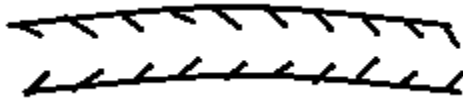

11. Which type of leaders is got through appointment?

12. Give one problem caused by over population on land.

13. Give any one positive effect of the early European explorers in Uganda

14. State any one benefit a school gets from the community.

15. Name the point marked A.

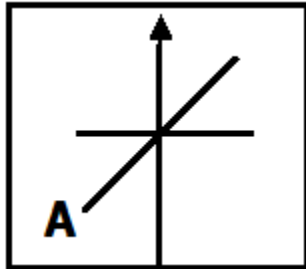

16. What body is responsible for conserving the environment in Uganda?

17. State any one way in way parents help to provide basic needs in a family.

18. How is the Uganda national motto important to the citizens?

19. Name one mountain in Africa that was formed by the process shown below.

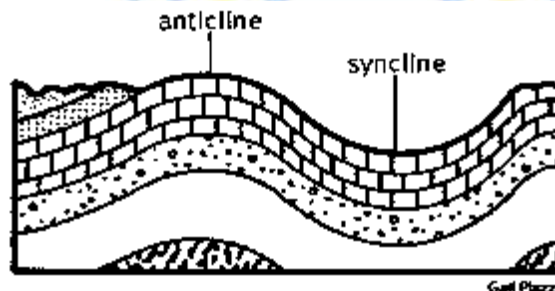

20. State one economic importance of historical sites in East Africa.

21. Give one way in which the construction of industries affects vegetation of an area.

22. State one role played by Captain Fredrick Lugard in the colonization of Uganda.

23. Give one reason why Rwanda joined the East Africa Community.
-
24. Write down any one economic activity carried out in the Equatorial region of Africa.
-
25. State one reason why children should know their rights.
-
26. Name the largest continent in the world.
-
27. What is natural vegetation?
-
28. State any one way in which ethnic groups can be classified.
-
29. State one way citizens promote democracy in East Africa.
-
30. Mention one role played by the District Agricultural Officer.
-
31. Write down one way people who live in highland areas carry out crop farming.
-
32. Who was the first Prime Minister of Uganda?
-
33. Mention any one factor that promotes peace and security at home.
-
34. The total population of town X is 16000 people. Calculate its population density if its land area is 40 Km²
-
35. State any one way of managing time at school.
-

For questions 36 – 40, answer Christianity or Islam “BUT NOT” both.

36. **Either:** Which angel brought the news about the birth of prophet John the Baptist?

Or: Name the angle that revealed the Qur’an to prophet Muhammad.

37. **Either:** State one importance of forgiveness to Christians.

Or: State one importance of forgiveness to Muslims.

38. **Either:** What is a church?

Or: What is a Mosque?

39. **Either:** Give one importance of a Bible in a Christian’s life.

Or: Give one importance of a Qur’an in a Muslim’s life.

40. **Either:** Give one way in which Jesus Christ showed concern for others.

Or: Give one way in which prophet Muhammad showed concern for others.

SECTION B (60 marks)

41.a). Write down two tribes under the River Lake Nilotes in Uganda.

(i) _____

(ii) _____

(b) Mention any one cause of the migration of the River – Lake Nilotes to Uganda.

(c) State one effect of the migration of the River – Lake Nilotes.

42(a) Name any two materials in the local environment used for making crafts.

(i) _____

(ii) _____

(b) Name the craft shown.



(c) Give the importance of the craft you have named above to people in the community.

43. **Study the sketch of Uganda given below and answer the questions that follow.**

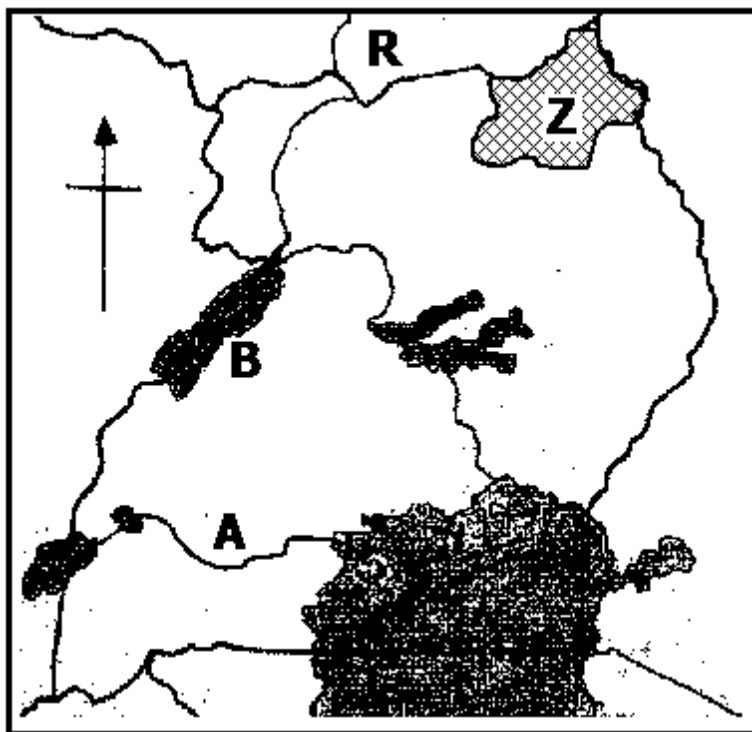

- (a) Name the physical features marked with letters:
 - (i) A _____
 - (ii) B _____
- (b) State any one reason why there are no crocodiles in the game park marked with letter Z.

- (c) State the similarity between Uganda and country R in terms of location.

- 44(a) Name the means of transport the Arab traders used to sail across the Indian Ocean.

- (b) Give any two reasons for the coming of the Arabs to East Africa.
 - (i) _____
 - (ii) _____
 - (c) State any one way in which the settlement of the Arabs at the East African coast affected the social life of the natives.

- 45(a) State any two problems faced by people while meeting their needs.
- (i) _____
 - (ii) _____
- (b) Give any two ways in which the government can solve the problems mentioned in (a) above.
- (i) _____
 - (ii) _____

- 46(a) State any two reasons why many people settle in highland areas of Africa.
- (i) _____
 - (ii) _____
- (b) Give one problem faced by people living in highland areas of Africa.

- (c) State one political importance of some lakes in Africa.

Study the sketch map of East Africa below and use it to answer question 47.

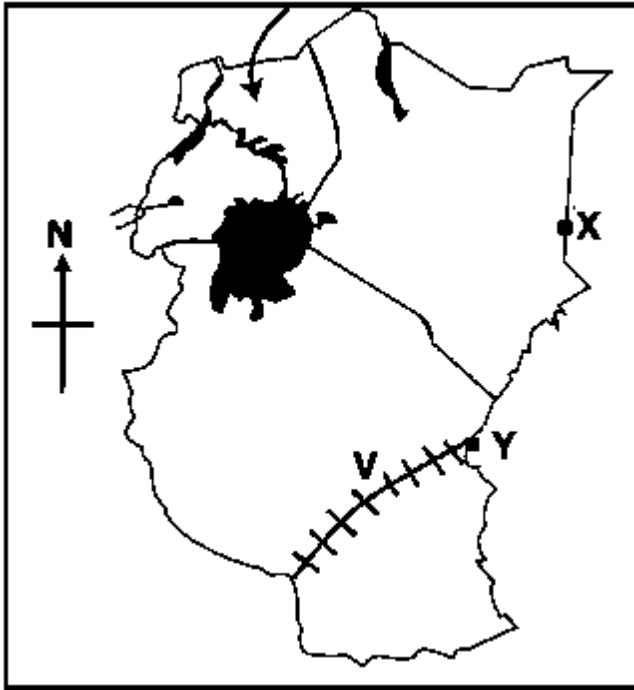

47(a) Name the sea ports marked with letters:

(i) Y _____

(ii) X _____

(b) State one way the East African countries benefit from the sea ports named above.

(c) A part from Tanzania, name any other country that benefits from railway line V.

48(a) Name the missionary who drew a sketch map of East Africa.

(b) Give any one problem the early missionaries faced in East Africa.

(c) Mention any one positive effect of missionary work in East Africa.

(d) State any one way in which missionaries promoted colonialism in Africa.

49(a) Name one type of budget.

(b) Which organ of the government approves a national budget?

(c) Give two reasons why a school should prepare a budget.

(i) _____

(ii) _____

50(a) State two causes of conflicts between the school and community.

(i) _____

(ii) _____

(b) Give two ways of promoting order in the school

(i) _____

(ii) _____

For questions 51 – 55, answer either Christianity or Islamic but Not both.

51. **Either:** (a) What do we call the fasting period for Christians?

(b) Give one reason why Christians fast.

(c) On which day do Christians begin fasting?

(d) For how long do Christians observed fasting?

Or: (a) Name the fasting period for Muslims?

(b) Give one reason why Muslims fast.

(c) When do Muslims begin fasting??

(d) For how long do Muslims fast?

52. **Either:** (a) What is suffering?

(b) Give one form of suffering.

(c) State one way in which HIV/ AIDS has led to suffering in societies.

(d) Which form of suffering is caused by lack of faith in God?

Or (a) What is suffering?

(b) Give one form of suffering.

(c) State one way HIV/ AIDS has led to suffering in societies.

(d) Which form of suffering is caused by lack of faith in Allah?

53. **Either:** (a) State any two ways of encouraging forgiveness.

(i)

(ii)

(b) Name the sacrament that encourages forgiveness among Christians

(c) Give one factor that made Joseph to be hated by his brothers.

Or: (a) State any two ways of encouraging forgiveness among Muslims

(i)

(ii)

(b) Name one pillar of Islam that encourages forgiveness.

(c) Give one factor that made Yusuf to be hated by his brothers.

54. **Either:** (a) Write down two promises God made to Jacob.

(i)

(ii)

(b) Give two lessons Christians learn from God's promises to Jacob.

(i) _____

(ii) _____

Or: (a) Write down two promises Allah made to Prophet Yaqub.

(i) _____

(ii) _____

(b) Give two lessons Muslims learn from the story of Prophet Yaqub.

(i) _____

(ii) _____

55. **Either: Match the items in list A to those in list B correctly.**

A

Christmas

Easter Sunday

Good Friday

Palm Sunday

(i) Christmas _____

(ii) Easter Sunday _____

(iii) Good Friday _____

(iv) Palm Sunday _____

B

death of Jesus Christ

Entry of Jesus to Jerusalem

Birth of Jesus Christ

Resurrection of Jesus.

Or: Match the items in list A to those in list B correctly.

A

Iddi El - fitri

Iddi - Aduha

Hijja

Hegira

(i) Idd – El – Ftri _____

(ii) Idd – Aduha _____

(iii) Hija _____

(iv) Hegira _____

B

prophet Muhammad Journey from Makkah to Medina

celebration for end of Ramathan

celebrated to remember Ibrahim's sacrifice to Allah

Pilgrimage made to Makkah.



KINGS WAY PRIMARY SCHOOL

P. 7 RECESS REVISION 2020-(SET THREE)

Basic Science and Health Education

Time allowed: 2 hours and 15 minutes

INDEX NUMBER

--	--	--	--	--	--	--	--	--

NAME: _____

Signature: _____

School _____

District _____

EXAMINER'S USE ONLY

A	
B	
TOTAL	

Read the following instructions carefully:

34. The paper is made up of section A and B.
35. Section A has 40 short answer questions (40 marks).
3. Section B has 15 questions (60 answers).
4. Answer ALL questions. All answers to both section A and B must be written in the spaces provided.
5. All answers must be written in blue ink.
6. Any handwriting that cannot easily be read will lead to loss of marks.
7. Unnecessary alteration of work may lead to loss of marks.
8. Do not write in the box marked "Examiner's use only".

PARENT'S COMMENT	SIGNATURE

SECTION A

1. Name the type of soil best for plant growth.

2. How does a dog protect itself from its enemies?

3. Give one item used to maintain proper personal hygiene.

4. Name one method of controlling vices in poultry.

The diagram below is of a garden tool. Use it to answer question 5 and 6.

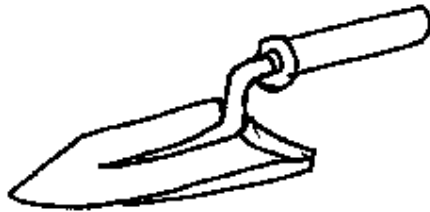

5. How is the garden tool useful to a farmer?

6. Write one way farmers care for their garden tools.

7. Give one example of a mammal that reproduces by laying eggs.

8. Which type of bee is fed on a royal jelly?

9. Name one raw material used by plants to make their own food.

10. State the first stage in food production.

11. Why does a dry leaf float on water?

12. Give one way a P.7 pupil can fight temptation of starting to smoke.

Study the diagram of a birds foot and use it to answer question 13 and

14.



13. Which group of birds have this type of foot?

14. Give one example of a bird with this type of foot.

15. Point out one danger of weeding crops on a rainy day.

16. State any one cause of road accidents.

17. Give any one main reason for mulching a vegetable garden.

18. How can loosening the string of guitar affect the pitch of the sound?

19. What are arthropods?

20. In which part of an insect are the legs found?

21. Name any one material used as litter in a poultry house.

22. Which vector spreads bilharzias flukes (germs)?

23. Why is a goat referred to as a ruminant?

24. How does deforestation cause soil erosion?

25. Give any one use of the sun in our everyday life.

26. What property of air is shown below?

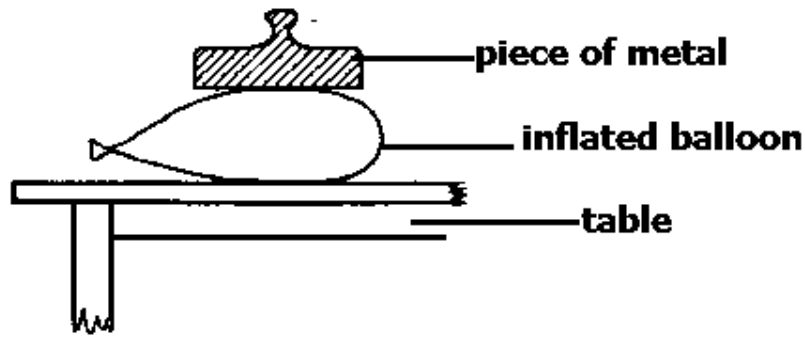

27. Give the agent of erosion in desert areas.

28. Write one example of an animal fibre.

29. Which part of a VIP latrine helps to trap flies?

30. Why do earthworms usually come out of the soil after it has rained?

The diagram below shows types of leaves. Study them and answer questions 31 and 32.

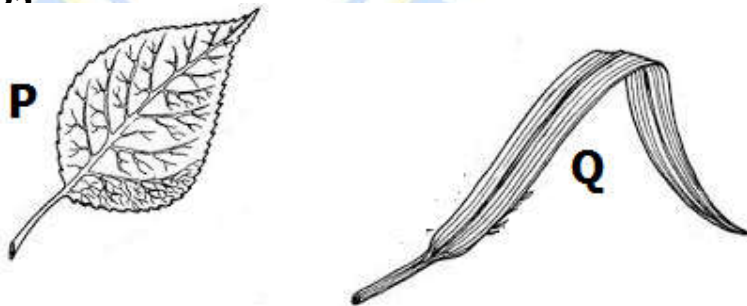

31. Name the type of leaf venation labelled Q.

32. Which of the leaves is from a dicotyledonous plant?

33. Give the method of finding the volume of irregular objects?

34. State one importance of keeping farm records.

35. What is meant by the word "shadow"?
-
36. Which activity of PHC is done after visiting a latrine?
-
37. What is the importance of sugar used in the making of sugar salt solution?
-
38. State the importance of cilia in the nose.
-
39. Which gas is used in the fire extinguishers?
-
40. Mention one way of preventing disease spread through 4F's germ path.
-

Section B (60 marks)

- 41(a) Name the instrument used to measure temperature.
-
- (b) Give the difference between heat and temperature.
-
- (c) Why is mercury the best liquid to be used in a clinical thermometer?
-
- (d) Give the normal human body temperature in degrees Fahrenheit
-
- 42(a) What is the function of the epiglottis during the process of digestion?
-
- (b) Apart from softening food, give one other function of the saliva.
-
- (c) Which class of food is first digested in the mouth?
-
- (d) Name any one disorder of the digestive system.
-

43. The diagram below is of an onion. Use it to answer questions that follow.

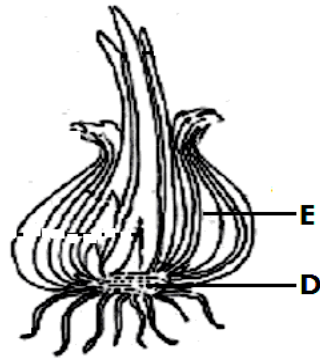

(a). Name the part marked D and E.

(i) D: _____

(ii) E: _____

(b) Give one way an onion can be propagated.

(c) From which part of an onion do roots grow?

44. The diagram below shows blood vessels. Use it to answer questions about it.

A	B
Culex mosquito	River blindness
Rat fleas	Dysentery
Black fly	Filariasis
Cockroach	Bubonic plague

(a) Culex mosquito

(b) Rat fleas

(c) Black fly

(d) Cockroach

45(a) Why is a bean plant called a legume?

(b) Apart from beans, give any two examples of a leguminous plant.

(i)

(ii)

(c) Give the importance of legumes in crop rotation.

46(a) Give a reason why some people keep rabbits apart from getting fur.

(b) Point out one way rabbits' fur is used by man.

(c) How long is the gestation period of rabbits?

(d) Write one disease among rabbits.

47. **The diagram shows the fertilized egg of a bird. Use it to answer the questions that follow**

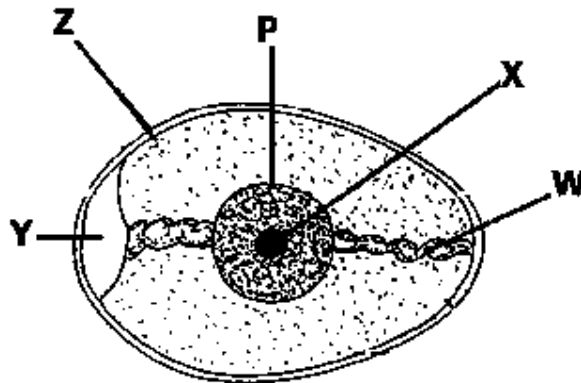

(a) Name the part marked X.

(b) Why is part Z porous?

(c) Which part of an egg acts as a shock absorber?

(d) What food value of we get from eating eggs?

48(a) Name the gaseous state of water.

(b) What do we call the change of state from solid directly to gas?

(c) What happens to the volume of water when it frees?

(d) Give one characteristic of a physical change.

49(a) Name the female reproductive cells in human beings.

(b) Where in the female reproductive system does fertilization take place?

(c) Give one function of the amniotic fluids during pregnancy.

(d) Name one disease of the reproductive system.

50(a) What is pollination?

(b) Name one type of pollination.

(c) Name the agent of pollination for flowers that open at night.

(d) Give one characteristic of insect pollinated flowers..

51(a) Why is a bat called a nocturnal animal?

(b) To which group of mammals does a leopard belong?

(c) Give two ways a leopard is adapted to its feeding habits.

(i)

(ii)

52. **The diagram shows musical instruments. Study them and answer the following questions.**

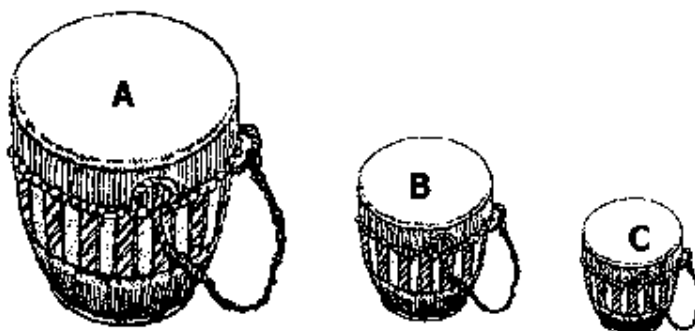

(a). Which drum will produce sound of the highest pitch?

(b) How is sound produced by the drums?

(c) To which group of musical instruments does a drum belong?

(d) Apart from a drum, name one musical instrument which belongs to the same group as a drum.

53. Complete the table of immunization shown below.

Disease	Vaccine	Age	Site of immunisation
Polio	_____	At birth	Mouth
Measles	Measles vaccine	_____	Left upper arm
_____	DPT vaccine	3 ½ months	Left upper thigh
Tuberculosis	BCG vaccine	at birth	_____

54(a) What name is given to a mixture of two or more metals?

(b) Give any one common mixture of metals.

(c) Why is coal regarded as a fuel?

(d) How does painting prevent rusting of metals?

55(a) Dehydration is prevented by giving the patient sugar salt solution Give the four main steps in making sugar salt solution.

(i) _____

(i) _____

(ii) _____

(iv) _____

