

MAGNETISM

A magnet is a piece of metal that attracts other metals.

It has two poles i.e. North Pole and South Pole

A pole

This is a point or an area in a magnet where the attractive power seems to be concentrated.

Magnetic material

This is a material which has the property of being attracted or repelled by a magnet e.g. iron, steel, nickel e.t.c

Note: copper and brass are non-magnetic

Non-magnetic materials

These are materials which cannot be attracted or repelled by a magnet e.g. copper, brass, wood, plastic e.t.c.

Ferro-magnetic materials

These are materials which acquire strong magnetism e.g. iron, steel

Para-magnetic materials

These are materials which acquire weak magnetism.

Laws of magnetism

- Unlike poles attract
- Like poles repel

The domain theory of magnetism

It assumes that if a magnet is broken into two equal parts, each part has a North and South Pole but the magnetism of each part is reduced to half the magnetism of the original magnet. Further divisions reduce the magnetism to produce the North and South poles.

It is again assumed that the smallest magnet (Dipole) or atomic magnet also has a North and South Pole.

In a magnetic material, molecular magnets arrange themselves in a particular ordered direction. These groups are called **Domains**.

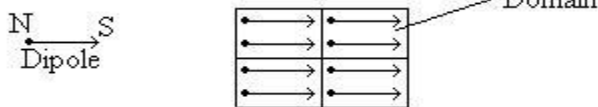

And in un-magnetized state, the molecular magnets are arranged randomly.

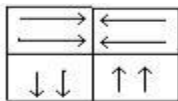

Qn: Which of the following shows a piece of material in a magnetized condition?

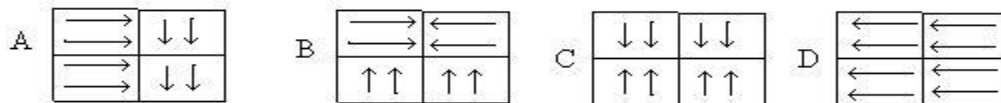

Magnetic saturation

When a magnetic material is magnetized, it reaches a point where it can not be magnetized further. This is called **magnetic saturation**.

OR

It is the limit to the strength of a magnet.

Methods of magnetizing a magnet

- Single touch method
- Divided touch method
- Electrical method using direct current.

Single touch method

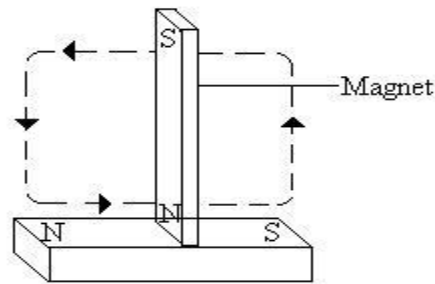

In this method, the steel bar is stroked from end to end several times in one direction with one pole of a magnet.

The polarity produced at the end of the bar is of the opposite kind to that of the stroking pole.

Double touch method

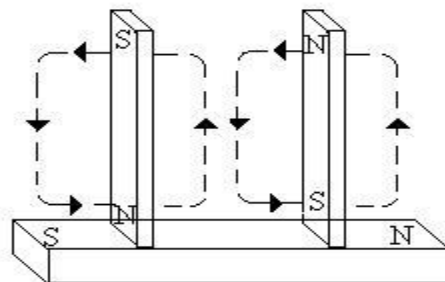

In this method, the steel bar is stroked from the centre outwardly with unlike poles of the two magnets.

The polarity produced at the end of the bar is also of the opposite kind to that of the stroking pole.

Electrical method

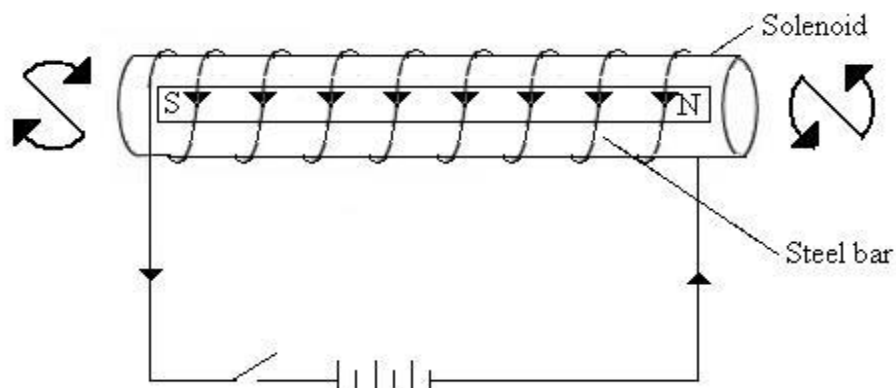

The material to be magnetized is inserted into a solenoid to which a steady d.c is flowing. The current is switched on for a short time.

When the steel bar is removed, it is found to be magnetized.

The current flowing in the same direction makes the atomic magnets in the Domains to point in the direction.

The polarity of the steel bar depends on the direction in which the current is flowing.

If on looking at the end of the solenoid, the current is flowing in a clockwise direction, that will be a **South Pole** and if it is flowing in an anti-clockwise direction, then that will be the **North Pole**.

Demagnetization

It is the process by which a magnet loses its magnetism. i.e. the atomic magnets are now in a random arrangement.

It can be demagnetized by:

- Heating and allowing it to cool in an East-West direction.
- Hammering/treating it roughly
- By electrical method using a.c

Note: the demagnetized magnet should be removed in an East-West direction to avoid magnetization by the earth field.

Testing the polarity of a magnet

The polarity of a magnet can be tested by bringing its poles in turn to the known poles of the suspended magnet.

The following is a summary of results

	North Pole	South Pole	Magnetic Substance
North Pole	Repulsion	Attraction	Attraction
South Pole	Attraction	Repulsion	Attraction
Magnetic Substances	Attraction	Attraction	No effect

Repulsion will indicate similar polarity. Therefore the only true test for polarity is “Repulsion”

Induced magnetism

A piece of un-magnetized steel/iron becomes magnetized when either near or in contact with a pole of a magnet. This is a process called induced magnetism. The end nearest to the pole of the magnet acquires an opposite pole.

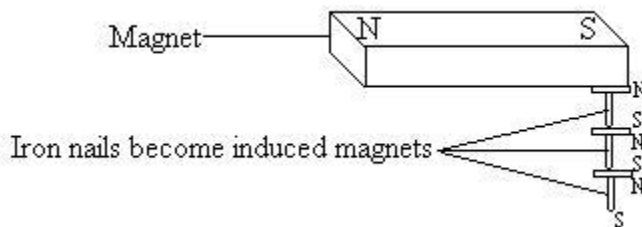

Magnetic fields

A magnetic

field is a region

or space around a magnet where a magnetic force is experienced by another magnet.

The magnetic field is represented by magnetic field lines/lines of force/magnetic flux.

These lines move from North (N) to South (S) Pole of the magnet.

Magnetic lines of force do not intersect or touch and can pass through a non-magnetic substance.

Magnetic flux patterns

(a)

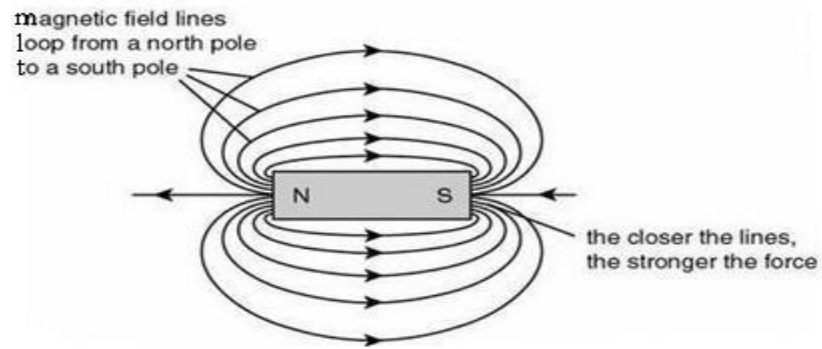

(b) Unlike poles close together (attraction)

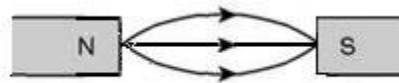

(c) Two like poles (repulsion)

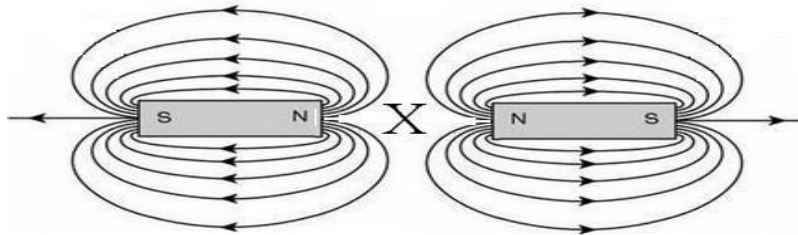

X –is a neutral Point

A neutral point to magnetic fields

A neutral point is a point in a magnetic field where the resultant magnetic field strength is zero (0). The opposing magnetic fields are of equal strength and therefore cancel out. The diagram below shows identical bar magnets placed close to each other.

(d)

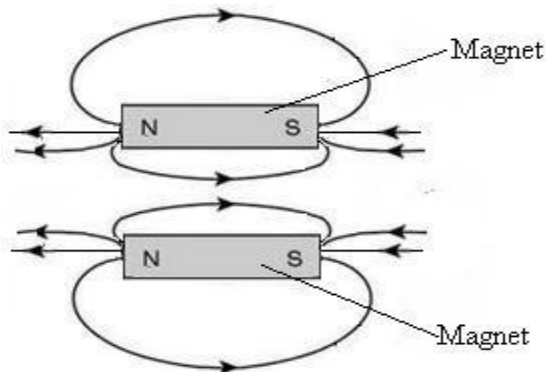

(e)

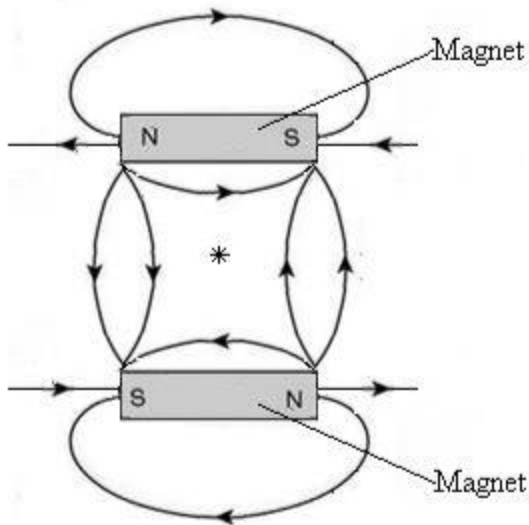

(f)

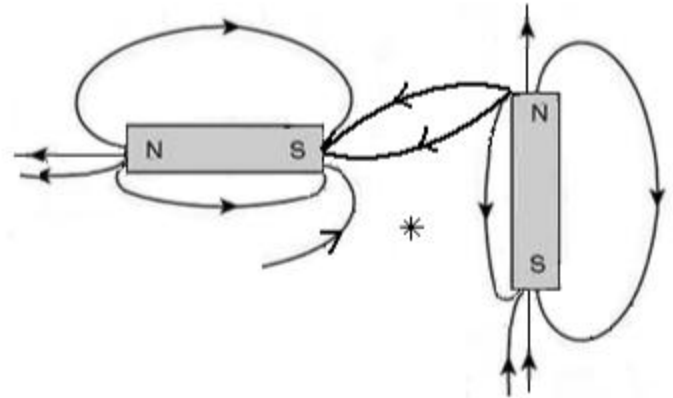

Magnetic screening (shielding)

Iron has the ability of drawing and concentrating all the flux from its surroundings through itself. It is thus said to be permeable to the magnetic flux than air is.

Iron in form of a ring causes the lines of force to pass through its walls and no magnetic flux passes the surrounding ring.

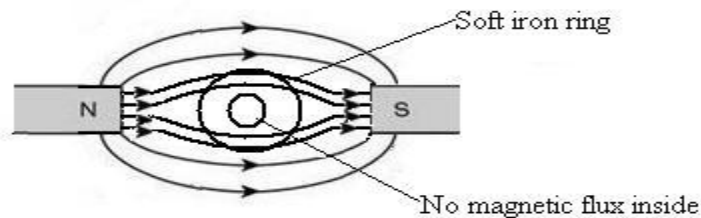

The space inside the ring is said to be shielded or screened from magnetic flux.

This property of iron is utilized for protecting delicate instruments which are easily affected by magnetic fields. They are enclosed within thin iron boxes.

Note: if a soft iron box is used, the following is obtained.

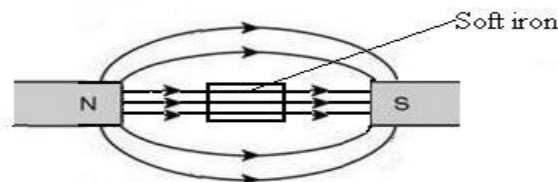

The earth's magnetic field

A freely suspended bar magnet always comes to rest pointing in the North-South direction. This is due to the magnetic field of the earth.

The earth behaves as though it contains a short bar magnet inclined at a small angle to its axis of rotation with its South Pole in the northern hemisphere (geographic North) and the North Pole pointing to the Southern hemisphere (geographic South)

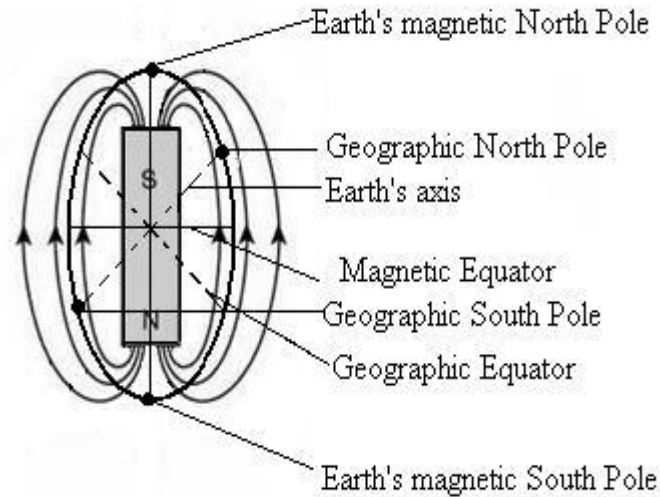

The angle between the magnetic and the geographic meridians is called the angle of declination.

At any place, the magnetic meridian is a vertical plane containing the magnetic axis of a freely suspended magnet at rest under the action of the earth's field.

The vertical plane passing through the earth's geographic poles is called the geographic meridian.

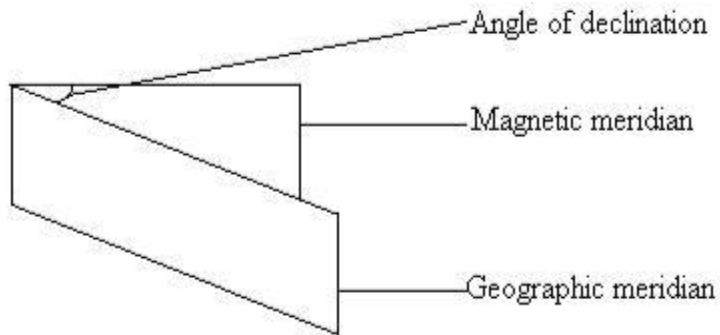

The angle between the horizontal and the direction of the magnetic field at the point is called the angle of dip. It varies from zero at the equator to 90^0 at the Northern hemisphere.

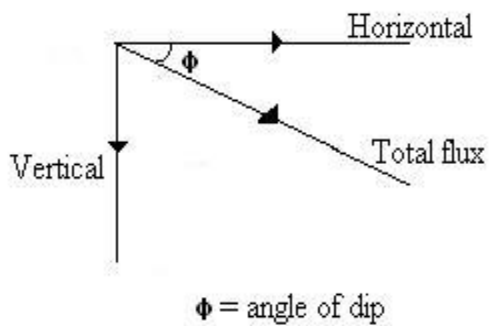

Magnetic flux pattern in the earth's field

The earth's magnetic field runs from the geographic South to the geographic North.

1. When the axis of a magnet is in the magnetic meridian and its south pole pointing north.

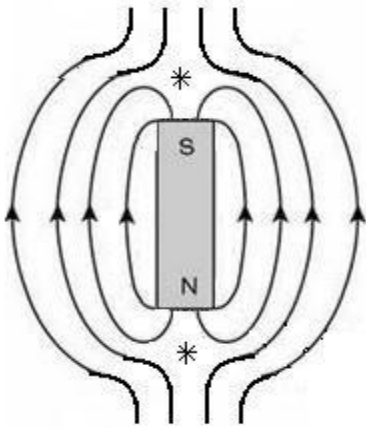

2. When the north Pole is pointing North

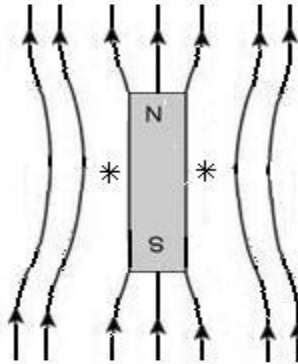

MAGNETIC EFFECT ON AN ELECTRIC CURRENT

If an electric current flows through a wire, a magnetic field is created around the wire.

The field pattern obtained can be studied by using iron filings or plotting compass.

It is found that the magnetic lines of force form concentric circles with the wire as the centre.

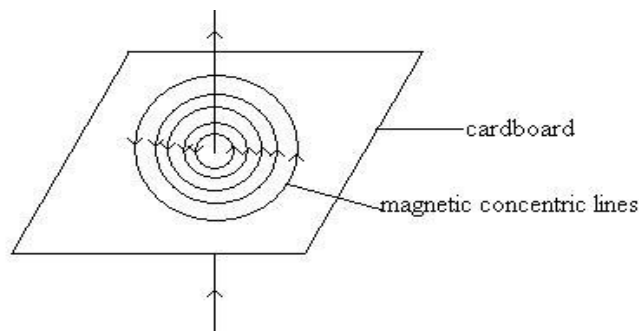

The direction of the magnetic flux depends on the direction of the current in the wire (conductor).

This can be determined by using the right hand grip rule which states that: “if a wire carrying current is imagined held in the right hand with the thumb pointing along the wire in the direction of the current, then the fingers will curl in the direction of the lines of force”.

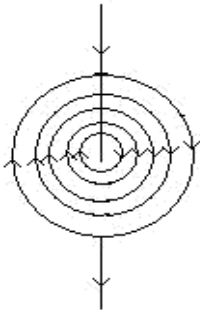

The direction can also be determined by the screw rule which states that: “if a right hand screw advances in the direction of the current, then the rotation of the screw is in the direction of the field”

Magnetic field due to a narrow circular coil

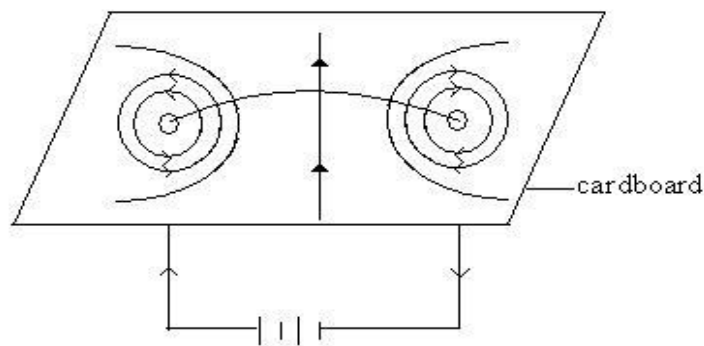

The field lines around each side are concentric circles. At the centre the field lines are straight.

Magnetic flux due to a current in a solenoid

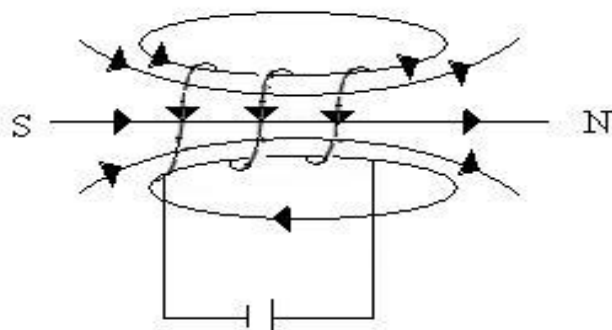

The field pattern due to a solenoid is similar to that of a bar magnet when current is switched on.

The direction of the field is determined as follows: “if the coil (solenoid) is viewed from one end and the current flows in an anticlockwise direction at that end, then the end is a North Pole and if the current flows in a clockwise direction, then that end is a south pole”

The strength of the flux density depends on:

- The current in the solenoid
- Number of turns

Electromagnets

An electromagnet is any current carrying conductor which acts as a magnet.

If a soft iron is placed in a solenoid, it will be strongly magnetized only when the current is flowing.

When the current is switched off, all the magnetism acquired is lost.

The soft iron inside the solenoid is acting as an electromagnet.

The strength of the field of an electromagnet can be increased by:

- Placing an iron core inside the coil.
- Increasing the magnitude of the current.
- Increasing the number of turns in the coil.

Applications of electromagnets

Electromagnets are used in:

- Lifting magnets
- Electric bells
- Telephone receivers
- Relay

Lifting magnets

They are mainly used for lifting and transporting heavy steel from one place to another in a factory. The coils are made of insulated copper wire wound on a U-shaped soft iron so that opposite polarity is produced. The opposite adjacent poles increase the lifting power of the electromagnet.

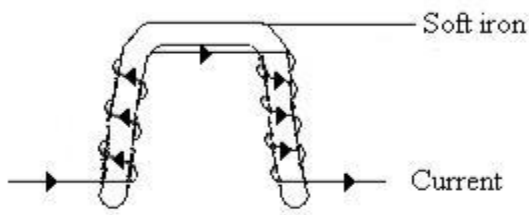

The coil is wound in opposite directions on each of the soft iron.

Electric bell

It consists of a hammer, a gong, soft iron armature, contact adjusting screw, a push switch, steel spring and an electromagnet made of two coils wound in opposite directions on the iron cores.

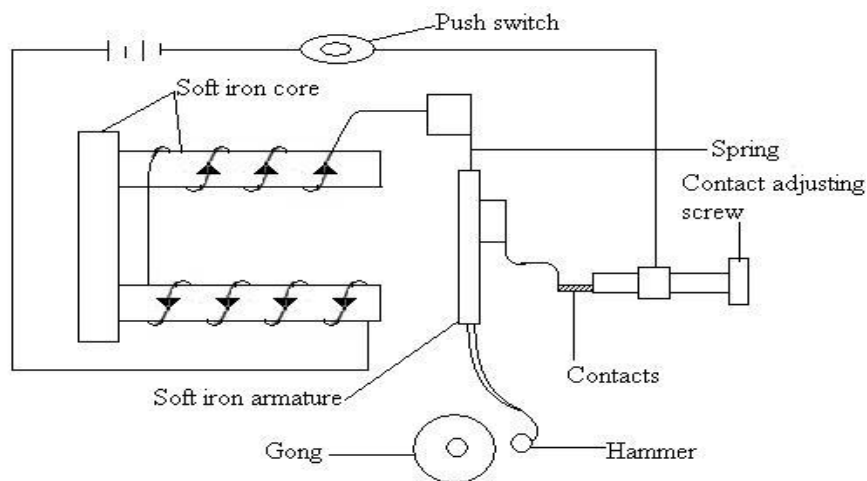

Action

When the switch is pressed, current flows through the electromagnet which becomes magnetized. It attracts the soft iron armature and hence breaking the contacts. This causes the hammer to strike the gong and sound is heard. As the armature moves, the current is broken causing the electromagnet to lose its magnetism.

The spring pulls the armature again to its original position and contact is made again. The process is repeated on and on hence a continuous sound will be heard.

Telephone receiver

It consists of an electromagnet which is mad of two coils wound in opposite directions on two soft iron cores, a diaphragm and a permanent magnet which attracts the diaphragm and keeps it under tension.

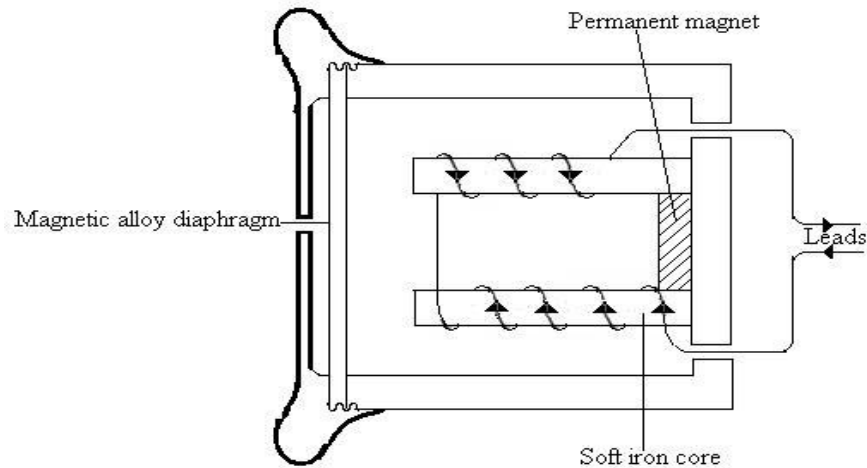

Action

When the phone is lifted, a steady current flows through the solenoids. However when a person speaks into the microphone on the other end, the sound energy he makes is converted into varying electrical energy of the same frequency as the original sound.

This is transferred through the cables to the receiver and magnetizes the electromagnet. The strength of the electromagnet varies according to the magnitude of the electric current which also depends on the original sound. This causes the magnetic alloy diaphragm which is under tension to have a varying pull. As a result, the diaphragm vibrates reproducing the vibration of the speech current and so the speech is reproduced.

FORCE ON A CONDUCTOR CARRYING CURRENT IN A MAGNETIC FIELD

If a conductor carrying current is placed between the poles of a powerful magnet, a force will act on it. The direction of the force depends on the direction of the field and the current. If the field or the current is reserved, the direction of the force also reverses.

Experiments show that no force acts on the conductor if the magnetic field is parallel to the conductor. The magnitude of the force on the conductor depends on;

- Current (I) in the conductor
- Strength of the magnetic field
- Length of the conductor in the field

The direction of the force can be found using Fleming's left hand rule which states that “if the thumb, the first and seconds of the left hand are held mutually at right angles to each other with the first finger in the direction of the field and the second finger in the direction of the current, then the thumb is in the direction of the force or motion of the conductor”.

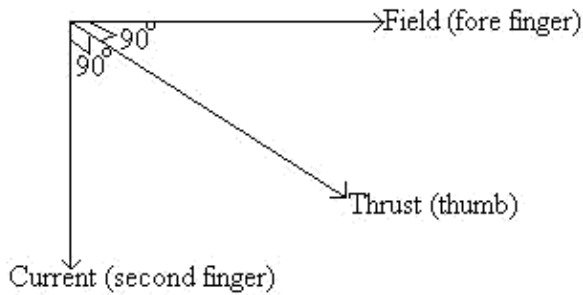

Interaction of magnetic fields

If a current carrying conductor is placed at right angles to an external uniform field and a current passes through the wire, a magnetic field appears as below.

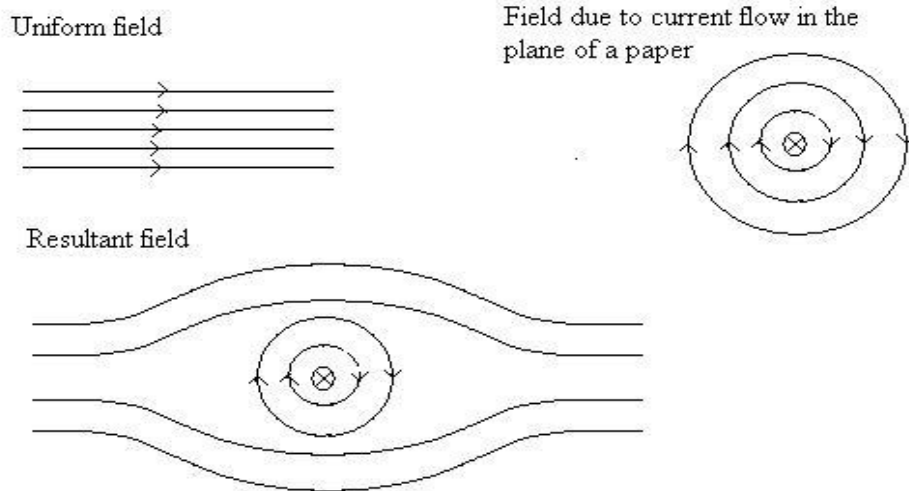

Note: current flowing into the paper is denoted by (X) and current flowing out of the paper is denoted by (•)



Force between two parallel current carrying conductors.

- (i) Current in the same direction.

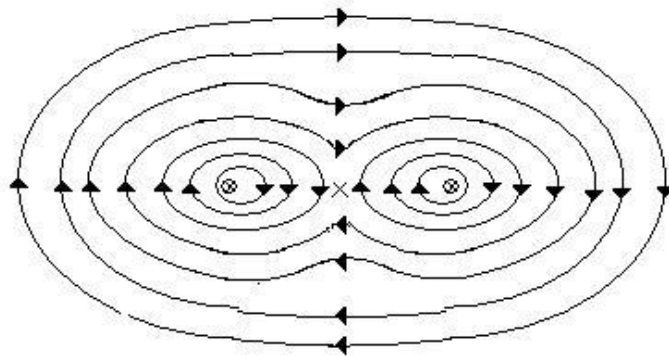

The two conductors will move towards each other i.e. attract each other.

(ii) Current in opposite direction

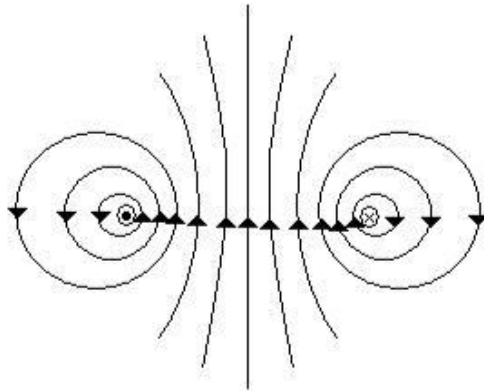

The conductors repel each other.

Applications of the force on a conductor

1. The simple direct current (d.c) motor

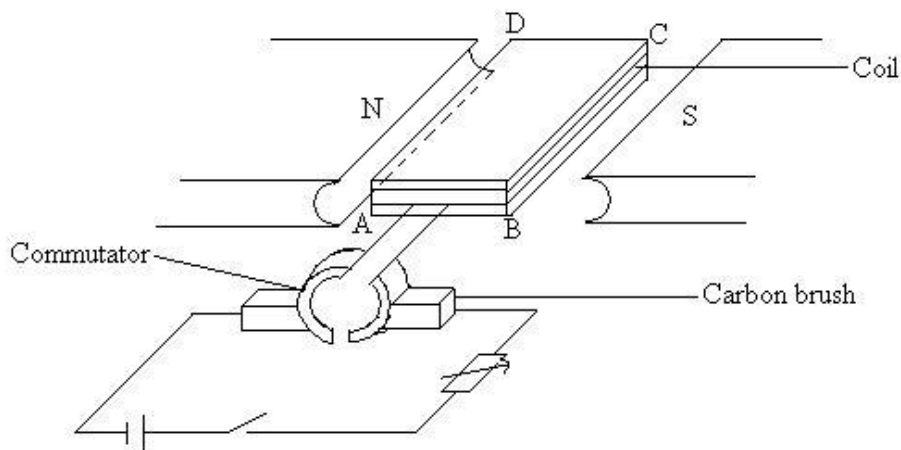

The d.c motor changes electrical energy to mechanical energy. It consists of a rectangular coil which can rotate about a fixed axis in a magnetic field provided by the permanent magnet. The ends of the coil are soldered to two halves of a copper ring (commutator), two carbon brushes press lightly against the commutators

Action

When current flows in the coil, side BC experiences a downward force and AD an upward force (Fleming's left hand rule).

The two forces constitute a couple which rotates the coil. When the coil reaches the vertical position, the brushes lose contact with the commutator and current is cut off. However the coil continues to rotate past this vertical position because of the momentum gained.

The current in the coil reverses as the brushes change contact with the commutator, side AD now experiences a downward force and BC an upward force. Thus the coil continues to rotate as long as the current is flowing.

Energy losses in a d.c motor

1. Energy losses in the winding of the armature (I^2R)
2. Eddy current losses
3. Energy losses due to friction e.g. between the brushes and the commutator.

These can be minimized by;

1. Using low resistance copper wire
2. Eddy currents are minimized by winding the coil on a laminated core.

3. Energy losses due to friction are minimized by lubrication

2. Moving coil Galvanometer

It is used to detect and measure an electric current and potential difference.

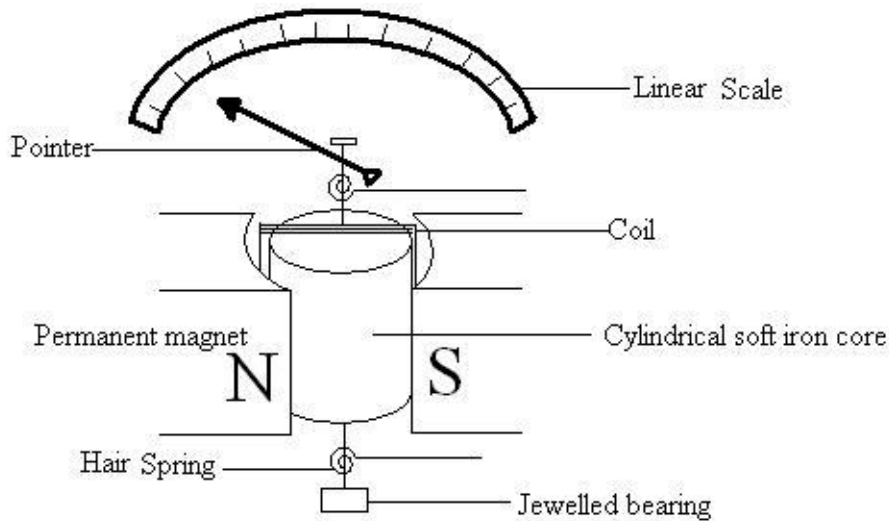

It consists of a rectangular coil with many insulated turns wound on an aluminum former, soft iron cylindrical core between the curved poles of a powerful permanent magnet, the springs which control the rotation of the coil, a pointer and a linear scale. The current is led in and out by two hair springs.

Action

When the current to be measured flows through the coil, a resultant magnetic field is set up. By Fleming's left hand rule, two equal and opposite parallel forces act on the two vertical sides of the coil. The two forces together form a deflection couple causing the coil to rotate until the deflecting couple is just balanced by the opposing couple setup by the hair springs.

As the coil rotates, the pointer moves with it and hence the magnitude of the current can be obtained from the linear scale.

Sensitivity of the moving coil galvanometer

A galvanometer is said to be sensitive if it can detect very small currents.

The sensitivity can be increased by;

- Using very strong magnet to provide a strong magnetic field
- Using very weak hair springs
- Suspending the coil so that it can turn freely
- Using a coil with many turns

Advantages

1. It has a linear scale because of the uniform field provided by the radial field
2. It can be made to measure different ranges of current and potential difference
3. External field around the galvanometer has no influence because the magnetic field between the magnets and the soft iron is very strong.

Conversion of a galvanometer to an ammeter

An ammeter is constructed in such a way that it has a very low resistance so that a large current passes through it.

To convert a galvanometer into an ammeter, a low resistance called a shunt is connected in parallel with it.

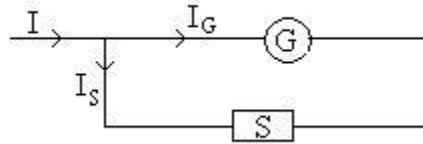

Most of the current will pass through the shunt and only a small part through the galvanometer.

Example

A moving coil galvanometer has a resistance of 5Ω and gives a full deflection of 15mA . How can it be converted into an ammeter to measure a maximum of 3A ?

Solution

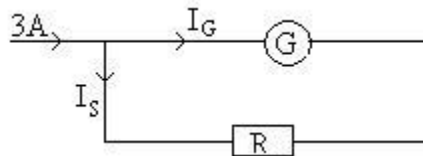

$$\begin{aligned} \text{Current through the galvanometer} &= 15\text{mA} \\ &= 15 \times 10^{-3} \text{ A} \\ I_G &= 15 \times 10^{-3} = 0.015\text{A} \\ I_S &= 3 - 0.015 = 2.985\text{A} \end{aligned}$$

P.d across the galvanometer is obtained by Ohm's law:

$$\begin{aligned} V &= IR \\ &= 0.015 \times 5 = 0.075\text{V} \end{aligned}$$

$$\begin{aligned} I_S R &= 0.075 \\ 2.985 R &= 0.075 \\ R &= \frac{0.075}{2.985} = 0.025\Omega \end{aligned}$$

Hence the shunt of resistance 0.025Ω should be connected in parallel with the galvanometer.

Conversion of a galvanometer to voltmeter

A voltmeter has a high resistance so that no current passes through it.

To convert a galvanometer to a voltmeter, a high resistance called a multiplier is connected in series with it.

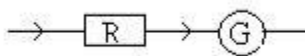

Example

In the above example, if the galvanometer is to measure a maximum p.d of 1.5V , the value of R can be obtained as below.

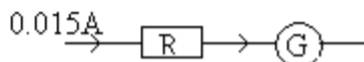

For full scale deflection, current through G = 0.015A.

$$\text{P.d across the galvanometer, } V=IR_G = 0.015 \times 5 = 0.075\text{V}$$

$$\text{P.d across } R = 1.5 - 0.075 = 1.425\text{V}$$

$$0.015R = 1.425$$

$$R = \frac{1.425}{0.015} = 95\Omega$$

Thus resistance of 95Ω must be connected in series with the galvanometer.

3. The moving coil loud speaker

It converts electrical energy into sound energy.

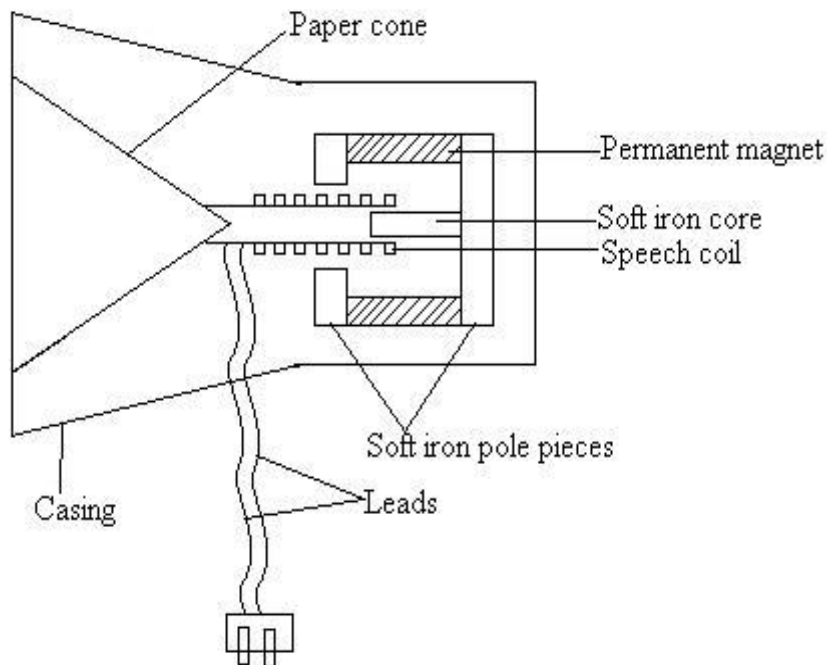

It consists of a light coil of wire known as a speech coil wound tightly round a cylindrical former to which a large thin cardboard cone is rapidly attached. The coil is in a radial magnetic field provided by the permanent magnet which has circular pole.

Action

Varying electric currents from an amplifier flow continuously in the speech coil through the leads. The varying current produces a varying electromagnetic force on the coil making it to vibrate at the same frequency as the current.

This makes the former and the paper cone to vibrate at the same frequency sending the surrounding air in vibration hence a loud note is heard.

The greater the electrical energy supplied to the coil, the louder the note produced.

Transformers

This is a device which transfers electrical energy from one circuit to another by electromagnetic induction.

If an a.c is passed through the primary coil an alternating magnetic flux is set up and it induces an alternating e.m.f in the secondary coil.

The primary e.m.f and secondary e.m.f is called input voltage and output voltage respectively.

Transformers are normally used in electrical appliances e.g. radio receivers, TV sets, battery chargers e.t.c. where the input voltage has to be changed or transformed.

The magnitude of the induced e.m.f is either smaller or larger in the secondary coil depending on the e.m.f applied to the primary coil and the number of turns in the two coils.

A transformer consists of primary and secondary coils wound on a laminated core of magnetically soft material (silicon iron or stalloy).

Step-up transformer

This is usually installed in power stations and transmission stations. It changes the voltage to a higher value by using more turns in the secondary coil than in the primary to the ratio of the output voltage required.

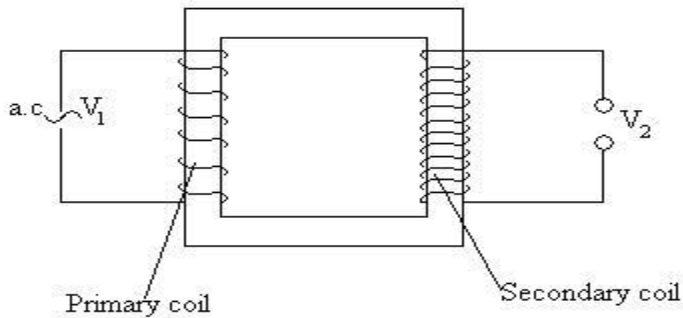

Step-down transformer

This is stationed near the consumers and in electrical appliances. It changes the output voltage to a lower value. The number of turns in the secondary coil is less than those in the primary coil.

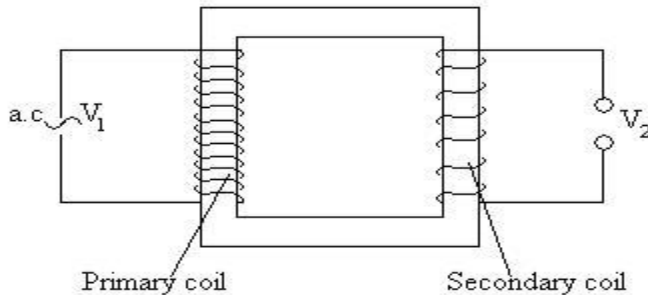

Causes and remedies of power losses in transformers Resistance

Current flowing through the primary and secondary coils will generate heat. Low resistance copper wires are used to reduce this effect.

Eddy currents

Power losses occur because the changing magnetic field will also induce currents in the iron core. These induced currents are known as eddy currents. Eddy currents will generate heat and reduce the transformer's efficiency. In order to reduce the formation of eddy currents, a laminated core is used.

Hysteresis

The core is magnetized and demagnetized alternately when AC current flows through the primary coil. Energy is lost during this process. This is known as Hysteresis. This effect is reduced by using a soft iron core.

Magnetic flux linkage

Not all primary flux completely link with the secondary coil. There may be a leakage of magnetic flux in the primary coil. A special core design is used in a transformer to ensure that all the primary

flux is linked with the secondary coil. The secondary coil can also be wound over the primary coil to ensure maximum linkage.

Power in transformers

The voltage induced in the secondary coil depends on the ratio of number of turns in the two coils.

$$\frac{\text{Secondary voltage}}{\text{Primary voltage}} = \frac{\text{Secondary turns}}{\text{Primary turns}} \text{ OR } \frac{V_S}{V_P} = \frac{n_S}{n_P}$$

The power in the two circuits, however is the same

Since power = current x voltage

Then

$$I_S V_S = I_P V_P \text{ OR } \frac{I_S}{I_P} = \frac{V_P}{V_S}$$

Efficiency of a transformer

If output power = $I_S V_S$

And input power = $I_P V_P$,

Since

$$\text{Efficiency} = \frac{\text{output power}}{\text{input power}} \times 100$$

$$\text{The efficiency of a transformer} = \frac{I_S V_S}{I_P V_P} \times 100$$

Alternating and Direct Current

Direct Current (DC) is a current which flows in one direction only. All batteries produce direct current.

Alternating Current (AC) is one which flows in two opposite directions alternately. This means that the direction of current flowing in a circuit is constantly being reversed back and forth.

The electric current supplied to our homes is alternating current. This comes from power plants that are operated by the electric company.

AC can be converted to DC by using AC/DC converter. This is used by many types of equipment such as computers.

One of the main advantages of a.c over d.c in power transmission is that an a.c can be easily and cheaply changed from one voltage to another by a transformer with very little loss of energy.

END

READ AND PREPARE FOR TEST WHICH WILL BE SENT TO YOU VIA THE WEBSITE