

# TWINKLING TOPS COVID-19 HOLIDAY WORK **SET 3**

## LEARNING AREA 5

NAME \_\_\_\_\_

1. Write a syllable to make a correct word.



\_\_\_\_\_d



\_\_\_\_\_n



bas\_\_\_\_\_t



\_\_\_\_\_n

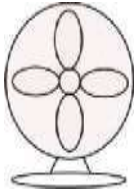

\_\_n



\_\_n

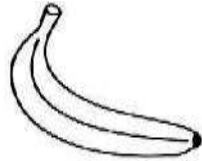

\_\_nana

\_\_st

2. Form word from the wheel.

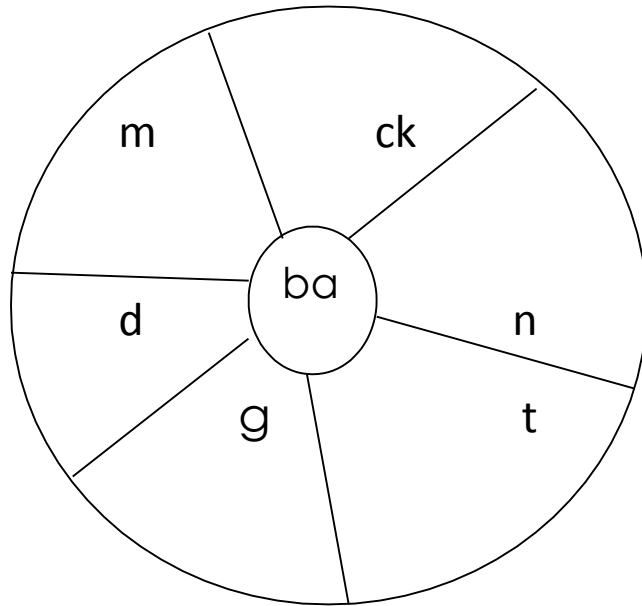

---

---

---

---

---

---

---

3. Form sentences using "This is a ...."



This is a tin.



---



---



---



---

4. Find words for the pictures from the puzzle

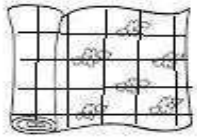
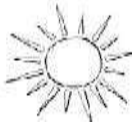

6



r	e	d	o	d
s	p	o	t	a
u	m	a	t	e
n	s	l	x	b
f	i	s	h	g

5. Read and draw

Peter has a hat \_\_\_\_\_

Sarah has a bag \_\_\_\_\_

A box and a cat \_\_\_\_\_

A mat and a net \_\_\_\_\_

6. Sound with action.

b            c            s            a

f            n            o            m

e            i            u            p

## LEARNING AREA 2 FOR TOP CLASS

NAME \_\_\_\_\_

1. Write your name in capital letters.

---

2. Change small to capital letters.

i \_\_\_\_\_

n \_\_\_\_\_

p \_\_\_\_\_

h \_\_\_\_\_

g \_\_\_\_\_

m \_\_\_\_\_

e \_\_\_\_\_

d \_\_\_\_\_

3. Read and draw the action.

carrying	dusting
writing	mopping

digging.

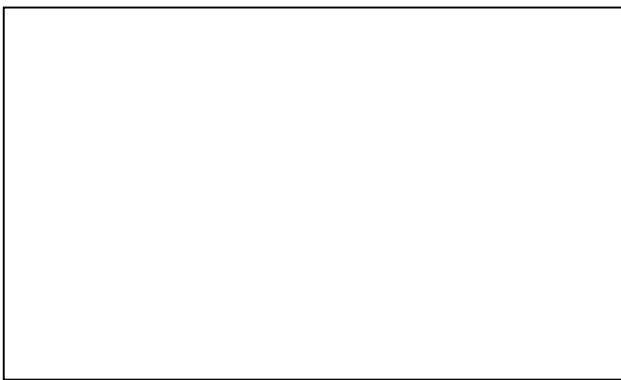



4. Read and draw.

table	chair
book	basket

flower.



5. Match people to their tools.

teacher



priest

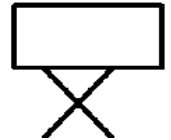

policeman



cook

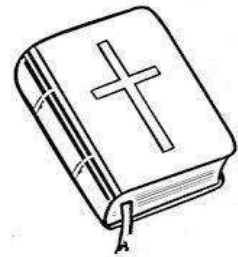

6. Fill the table.

<b>one</b>	<b>many</b>
cup	
	balls
	books
bed	
chair	
	trees

7. Match to the belongings.

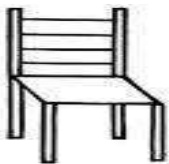

8. Colour by number.

1. blue.

2. yellow.

3. red.

4. green.

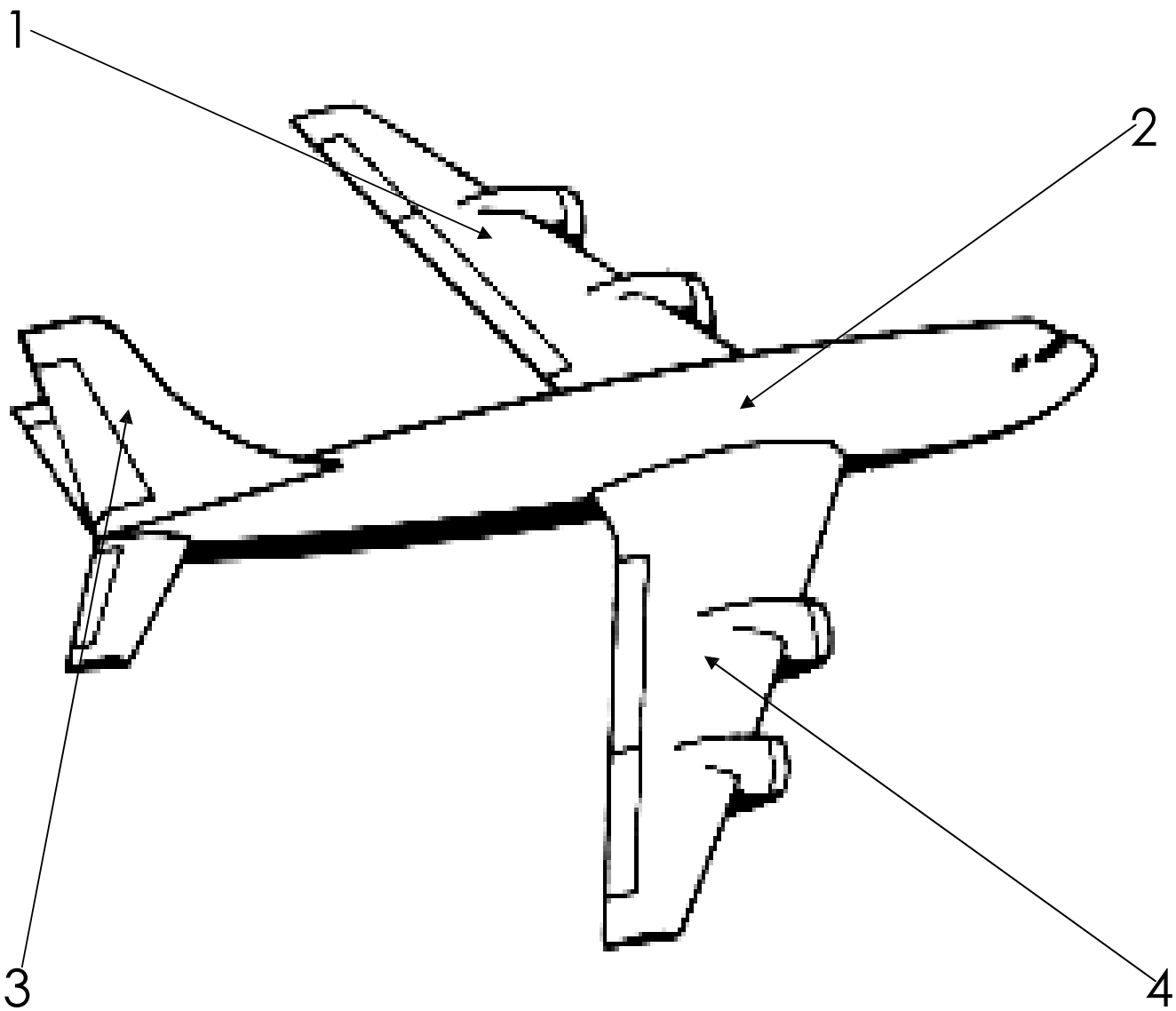

# LEARNING AREA 4 FOR TOP CLASS

NAME \_\_\_\_\_

1. Arrange the numbers in order.

4, 1, 2, 0, 5, 7, 10, 8, 3, 9, 6.

0, \_\_\_\_\_, \_\_\_\_\_, \_\_\_\_\_, \_\_\_\_\_, \_\_\_\_\_, \_\_\_\_\_, \_\_\_\_\_,  
\_\_\_\_\_, \_\_\_\_\_, \_\_\_\_\_.

2. Count and write the number.



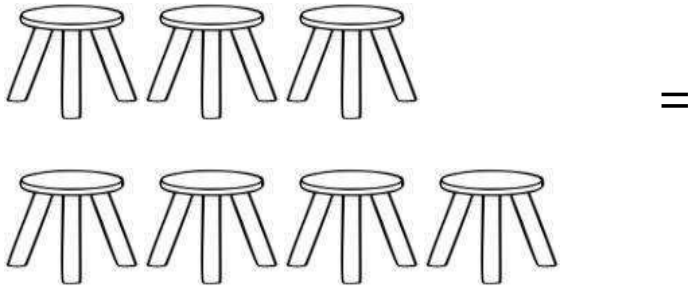

3. Write the numbers before, after and between.

\_\_\_\_\_ 6

7 \_\_\_\_\_

2 \_\_\_\_\_ 4

\_\_\_\_\_ 8

3 \_\_\_\_\_ 5

9 \_\_\_\_\_

#### 4.Add.

$$1 + 3 = 10$$

$$2 + 2 =$$

$$3 + 1 =$$

$$5 + 4 =$$

$$6 + 2 =$$

$$1 + 0 =$$



5. Make sets.

2 bags

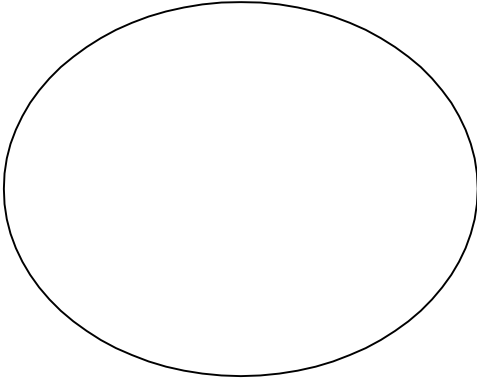

14 sticks

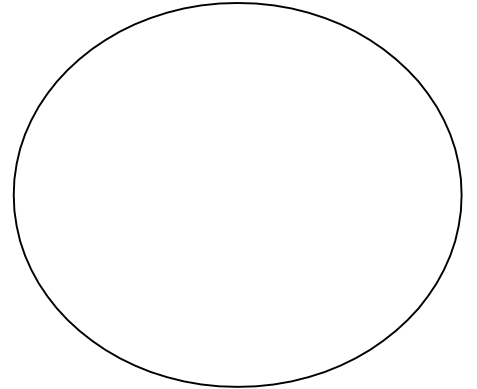

8 eggs

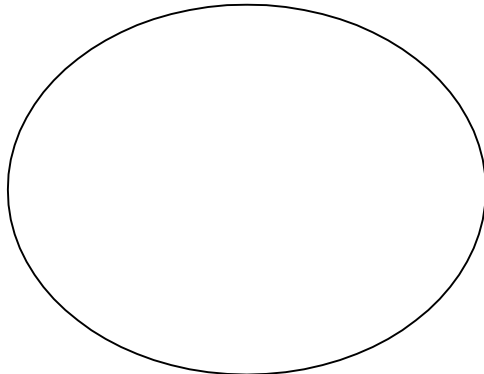

7 stones

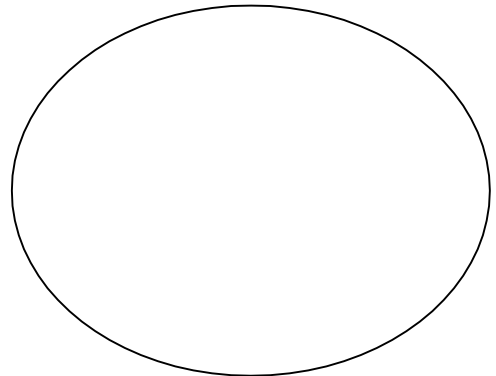

6. Name the shapes.

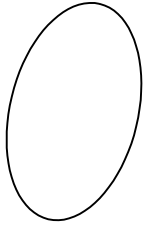

\_\_\_\_\_



\_\_\_\_\_

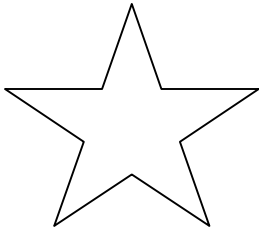

\_\_\_\_\_

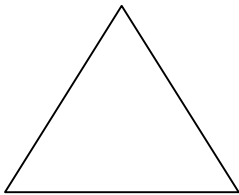

\_\_\_\_\_



\_\_\_\_\_

\_\_\_\_\_

**(cone, triangle, star, zigzag, oval, square)**

7. Draw for the numbers.

$$\int = 0$$

$$\int = 5$$

$$\int = 3$$

$$\int = 10$$

$$\int = 2$$

$$\int = 6$$

8. Tell the numbers.

**12**

**16**

**13**

**19**

**18**

**14**

**15**

**17**

**20**

# LEARNING AREA 3 FOR TOP CLASS

NAME \_\_\_\_\_

1. Circle the word for the pictures.

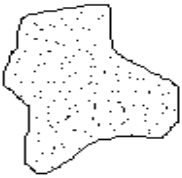

stone

box



girl

pin



cup

knife



brokenbottle

nail

2. Match the parts of the body to words.



nose



eye



ear



leg



fingers

3. Draw the things that gives us light.

moon

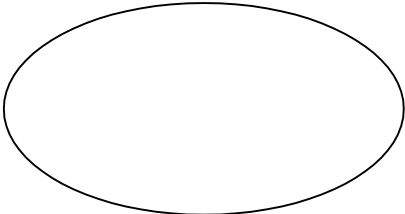

star

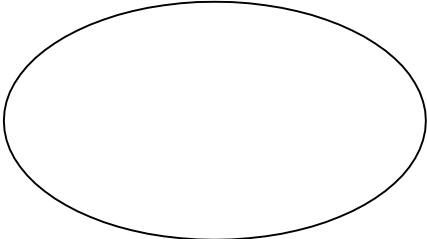

sun

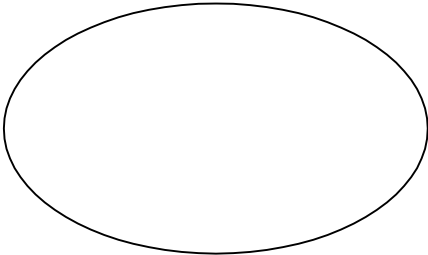

torch

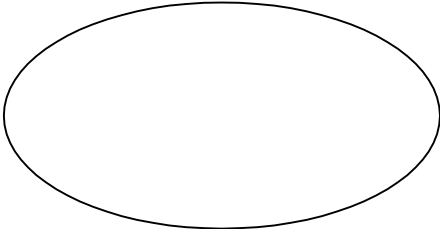

bulb

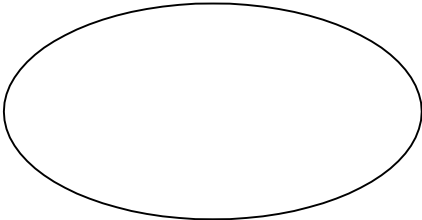

4. Tick the things we use to clean our bodies.

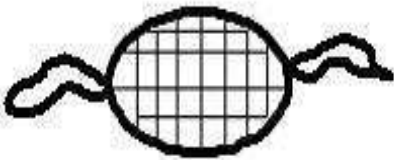
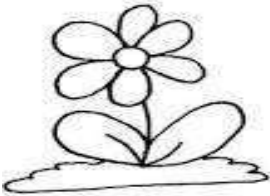
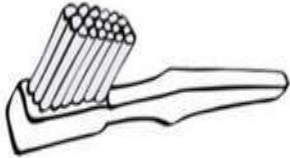

5. Shade the sun glasses.



Oral. (With help of the parent, tick correct with pencil)

We use,

- i. hands for?
- ii. eyes for?
- iii. ears for?
- iv. tongue for?
- v. mouth for?
- vi. legs for?
- vii. nose for?
- viii. why do we brush our teeth?
- ix. what do we use to comb our hair?
- x. why do we eat?



# LEARNING AREA 1 FOR TOP CLASS

NAME \_\_\_\_\_

1. Read and draw.

church	mosque
hospital	school
market	Children's park

2. Name the people at home.



\_\_\_\_\_



\_\_\_\_\_



\_\_\_\_\_

\_\_\_\_\_



\_\_\_\_\_



\_\_\_\_\_

**(grandfather, brother, father, baby, sister,  
grandmother, mother)**

### 3. Match people to their tools.

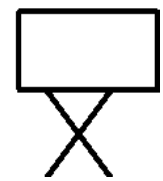

4. Ring the correct word for the picture.

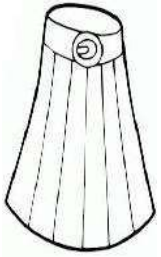

mat

skirt

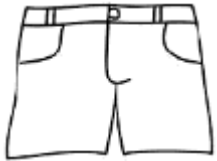

shorts

book



tree

trousers

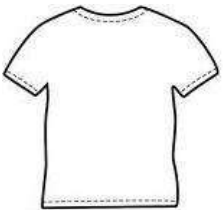

shirts

bed



dress

stone

5. What is this?

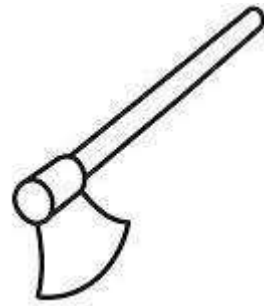

Oral. (With help of the parent, tick correct with pencil)

- i) What is your name?
- ii) In which class are you?
- iii) Who leads prayers in the?
  - a) mosque
  - b) church
- iv) Who are your teachers?
- v) Who is your director?
- vi) What is the colour of your uniform?
- vii) How many days make a week?

**END**